

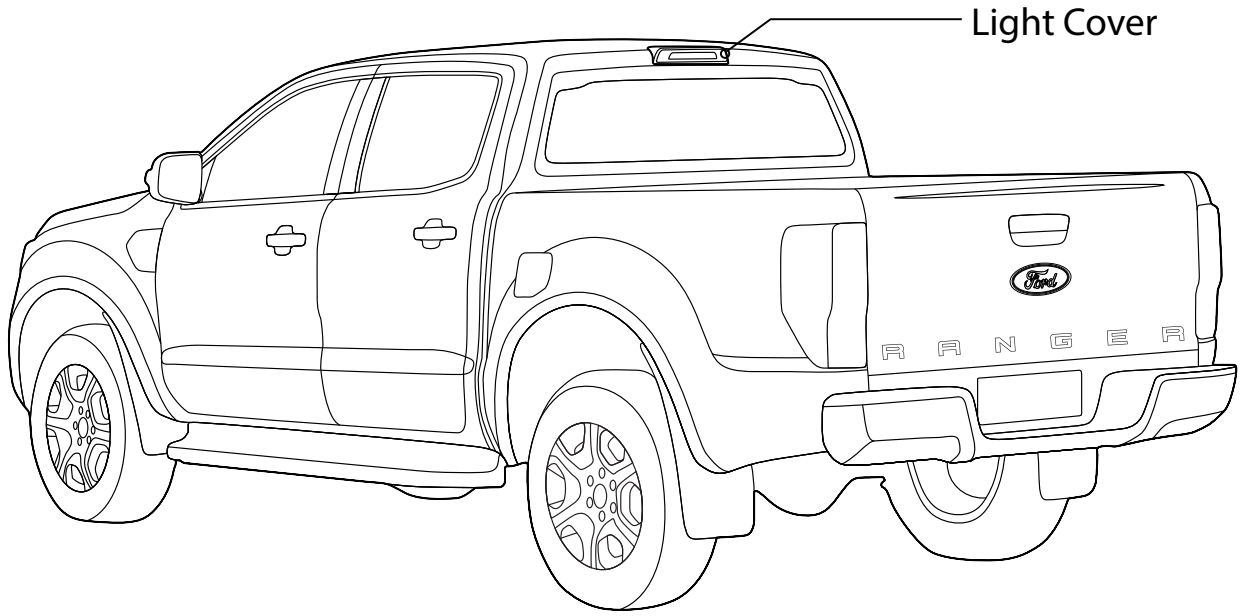

Installation Manual

For Ford Ranger 2012



EQUIPMENT

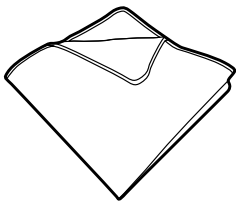

Fabric

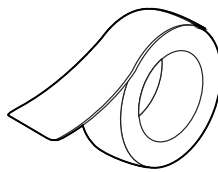

Masking Tape

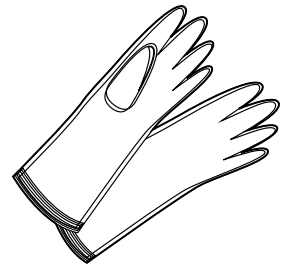

Handcover

TOOL

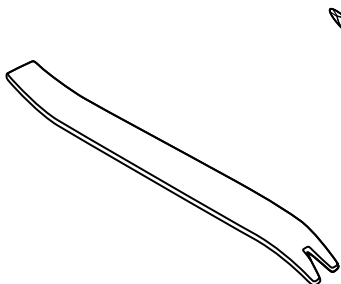

Plastic for Console Car

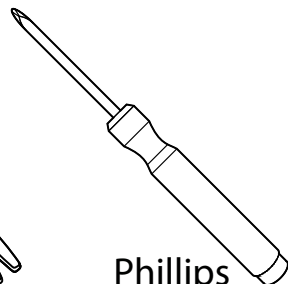

Phillips
Screwdriver

LIGHTCOVER

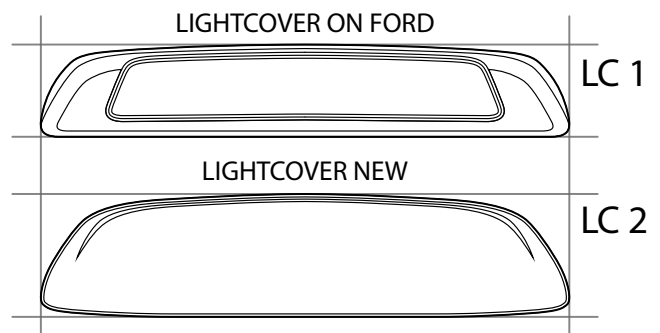

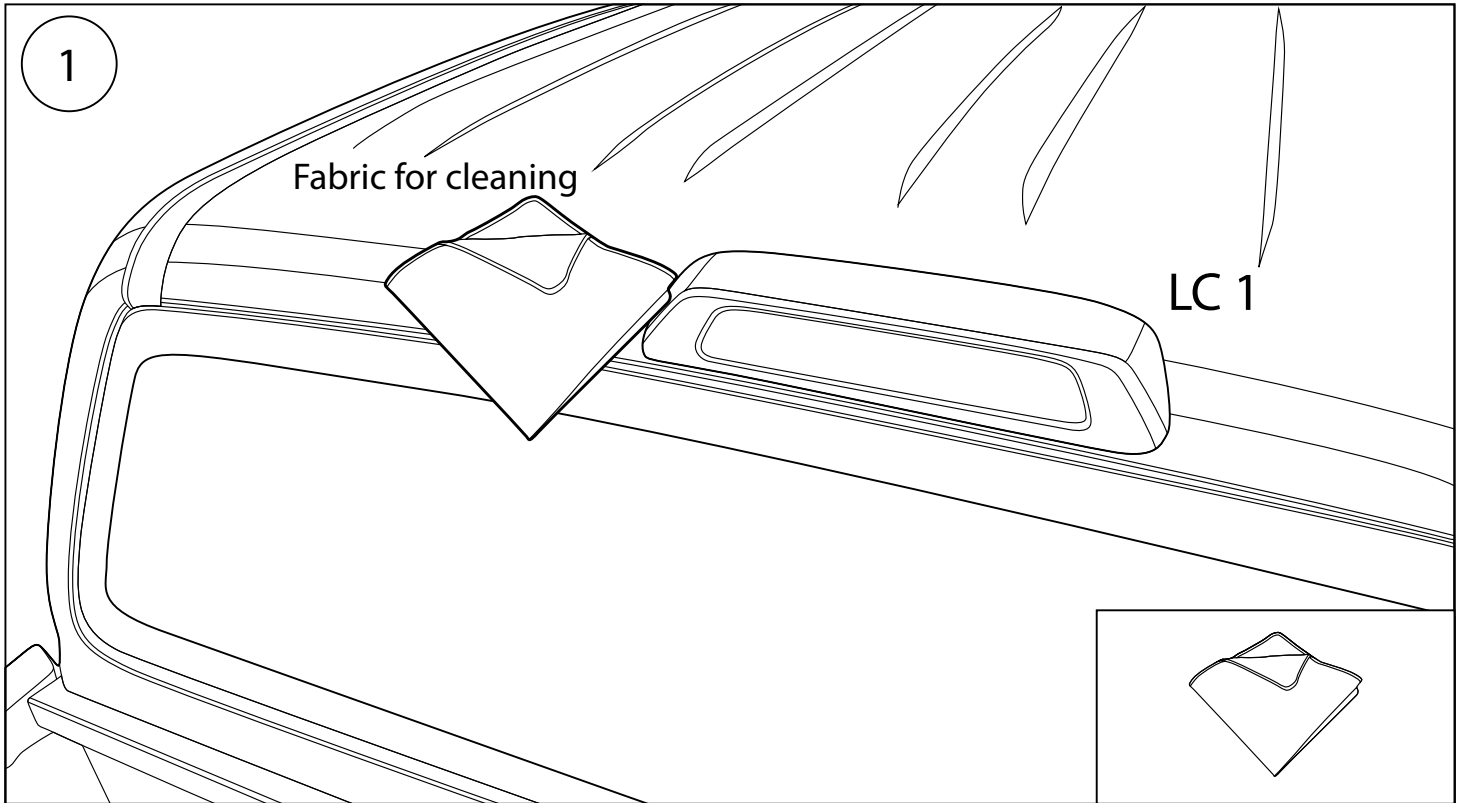

Cleaning the surface area of light cover on ford.

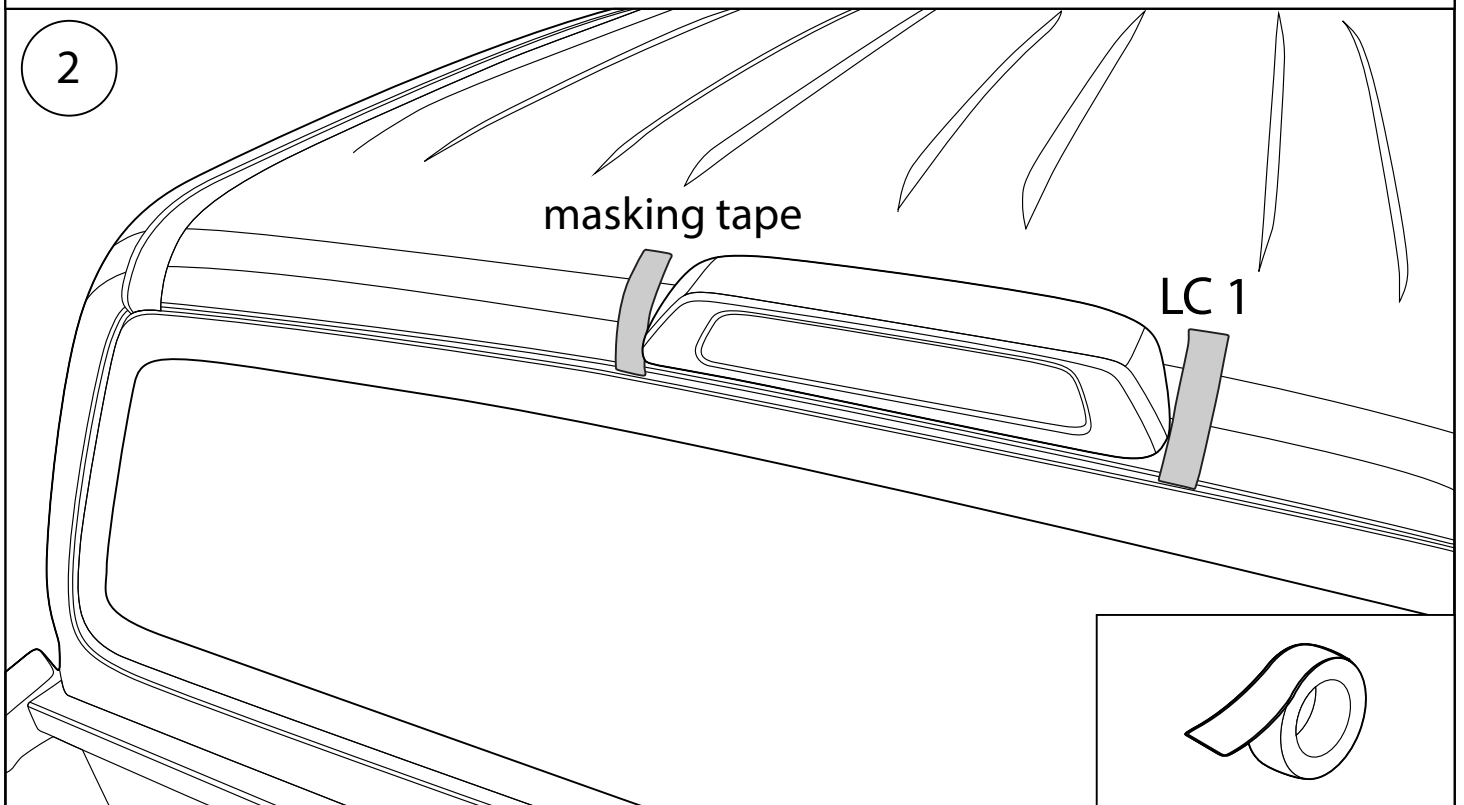

Stick the masking tape to measure a space of installation for new light cover.

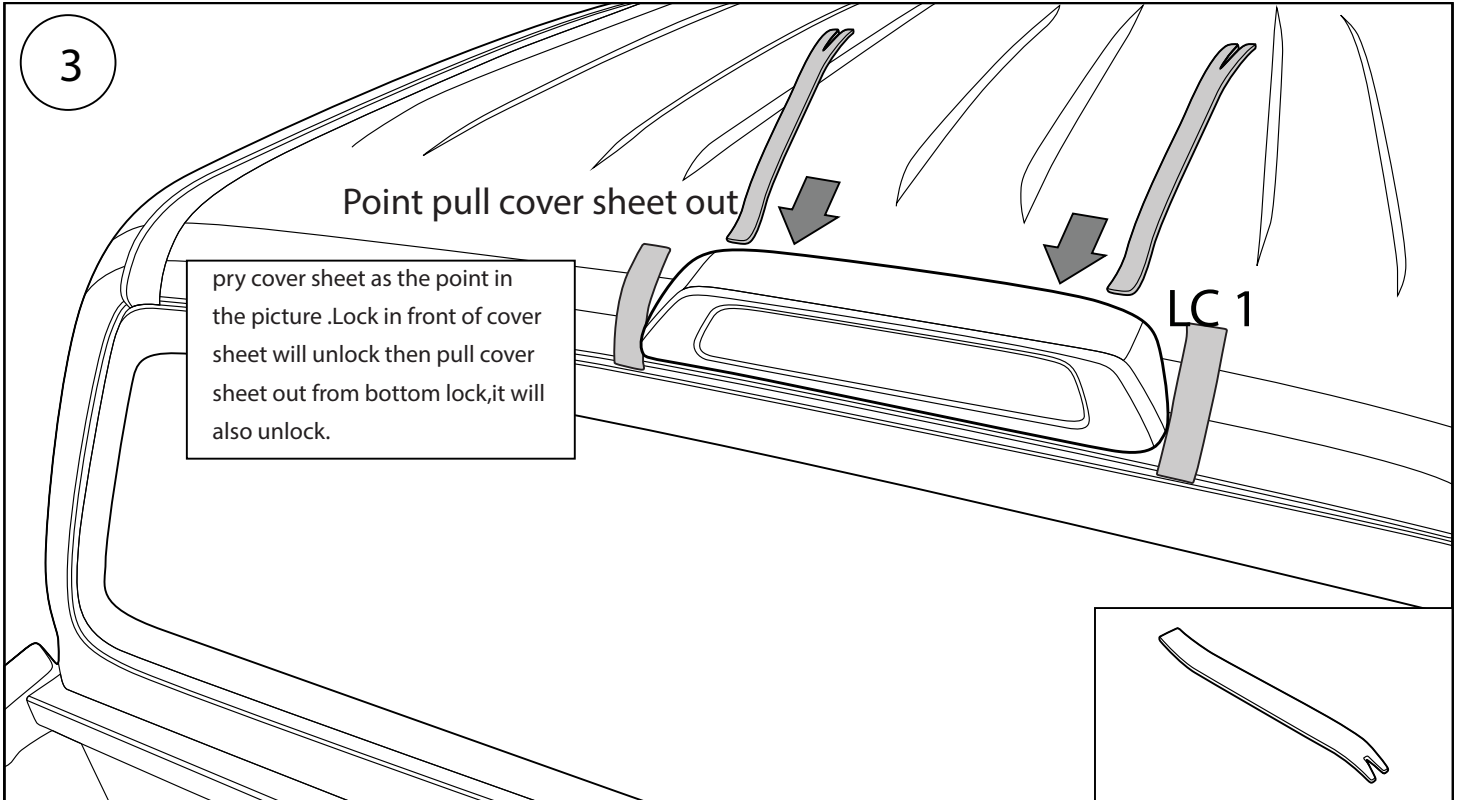

Using a plastic for console car pry a light cover on ford as picture above lock will unlock.

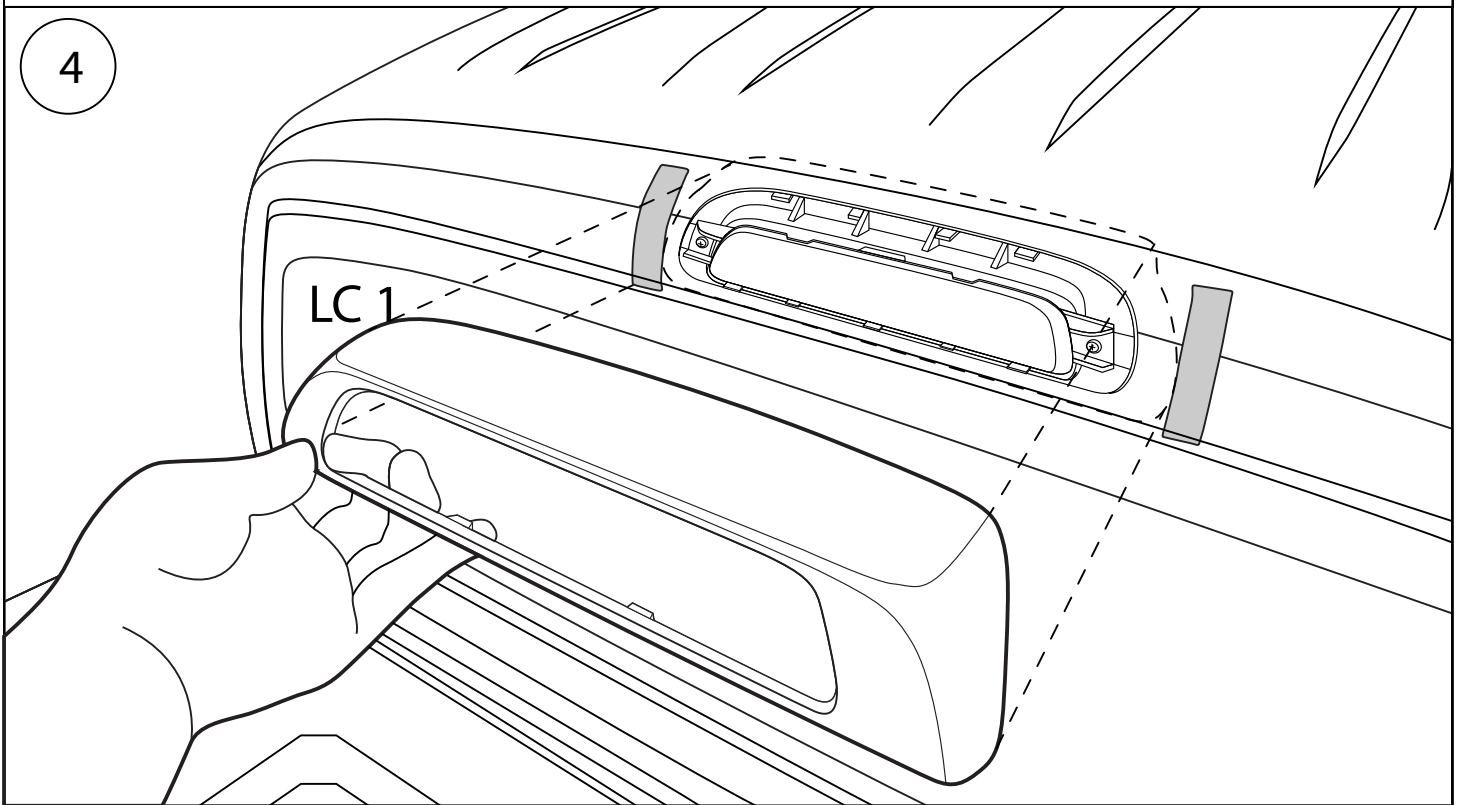

Pull a cover sheet out.

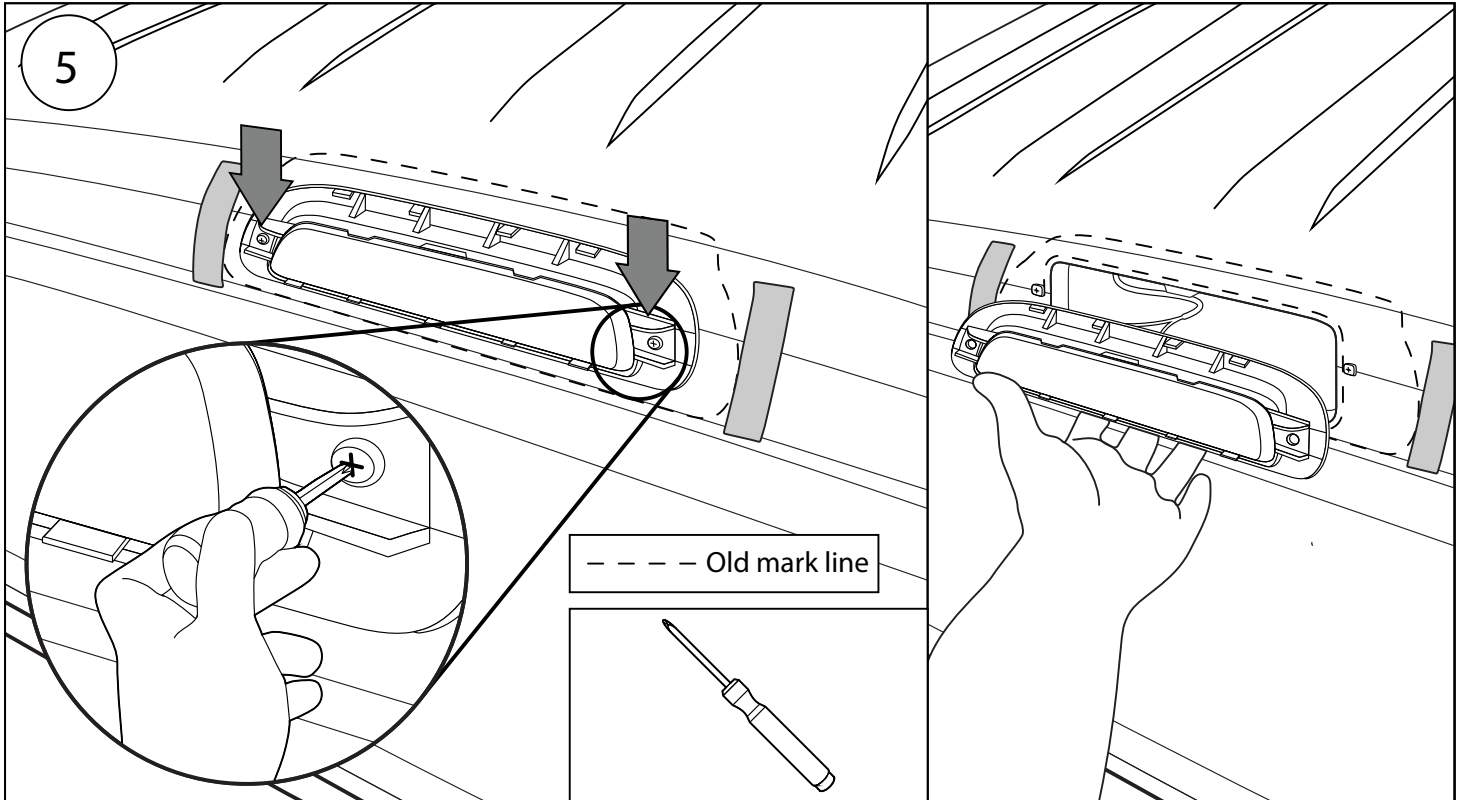

Use philips type screwdriver turn nut out on bolt position as in the picture.

Pull the electric cover panel out.

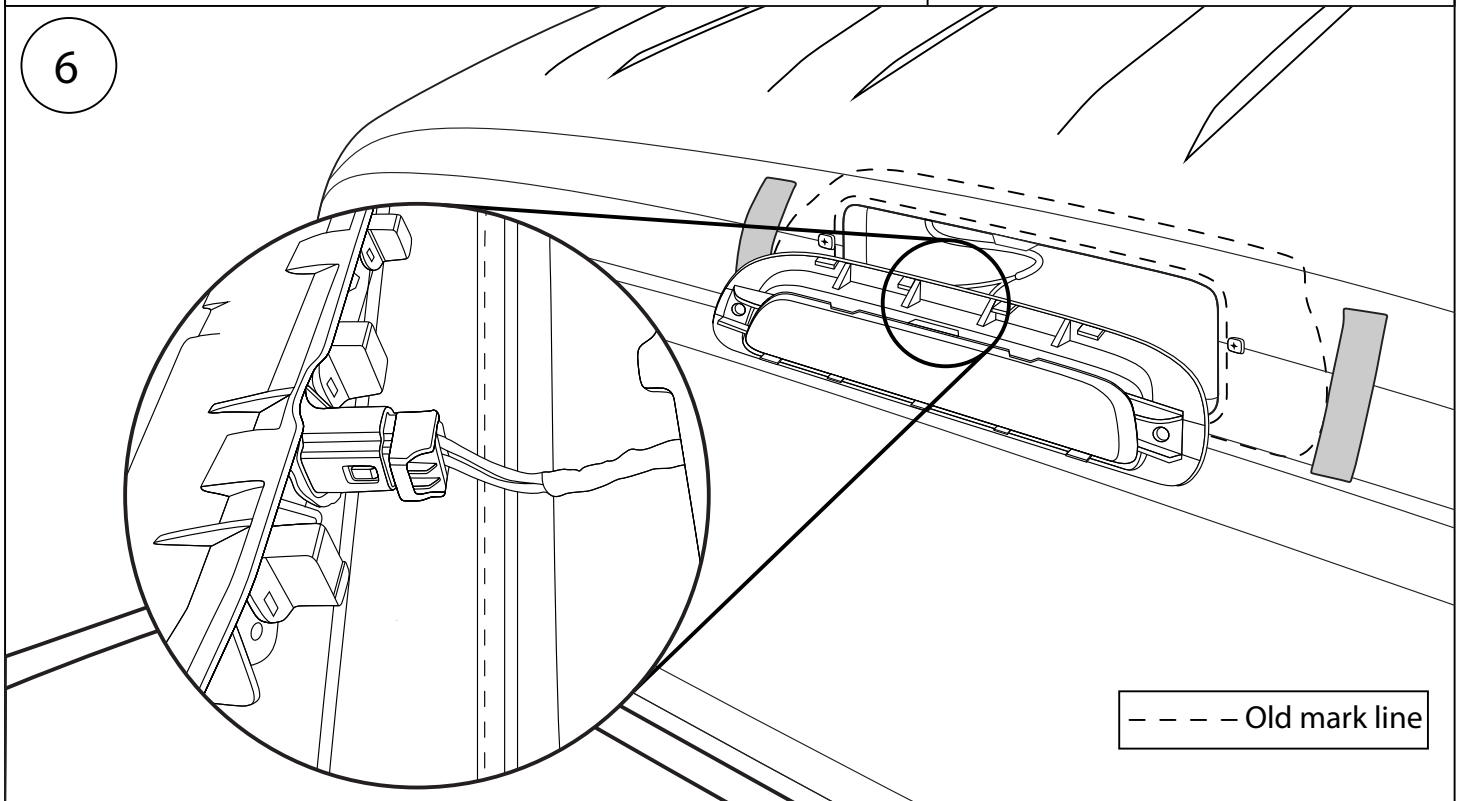

In the picture showing that pull the electric panel out, wiring of vehicle as still connecting.

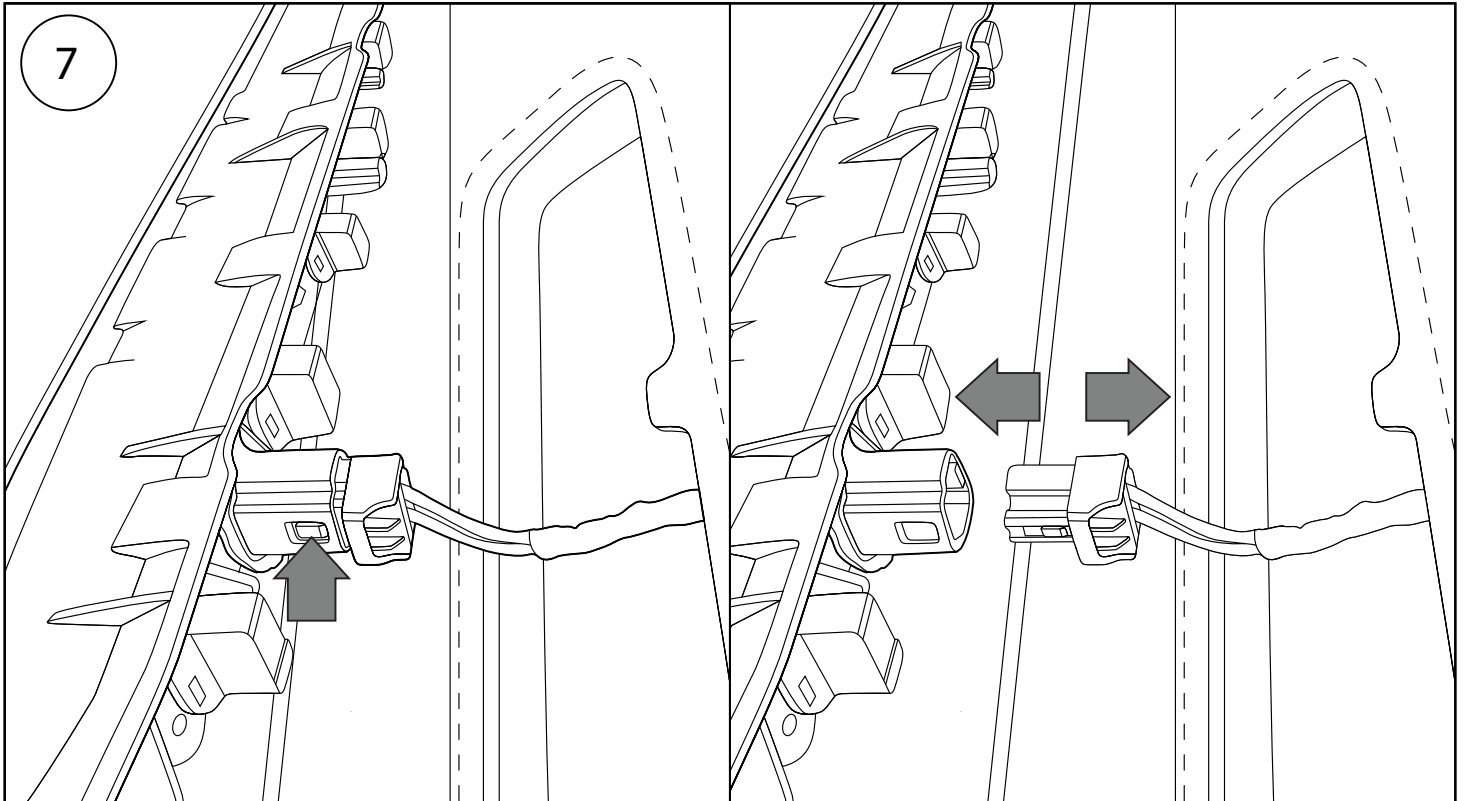

7

Press the position in the picture to take a wiring off a panel.

Pull a wiring out from electric cover panel.

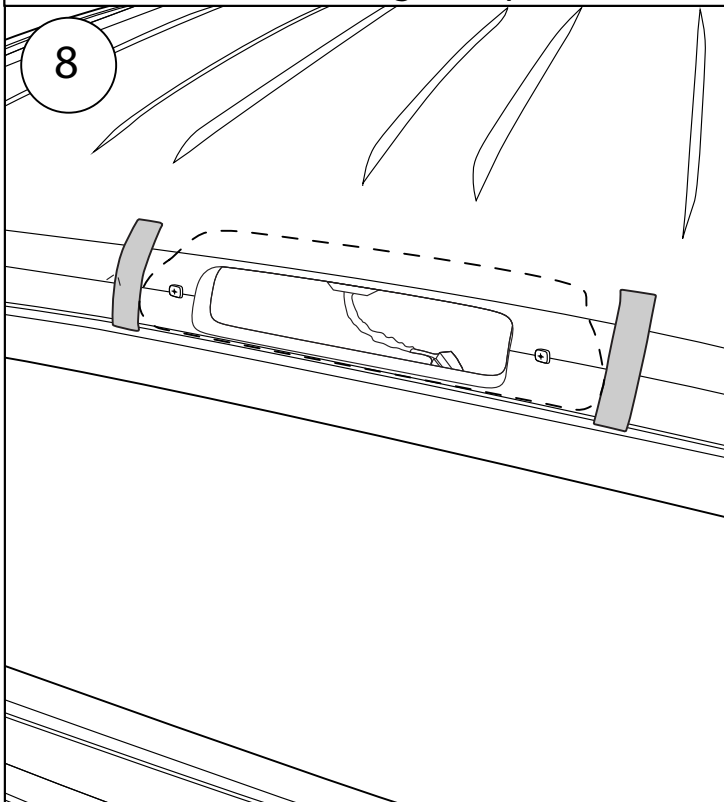

8

Keep a vehicle's wiring into space.

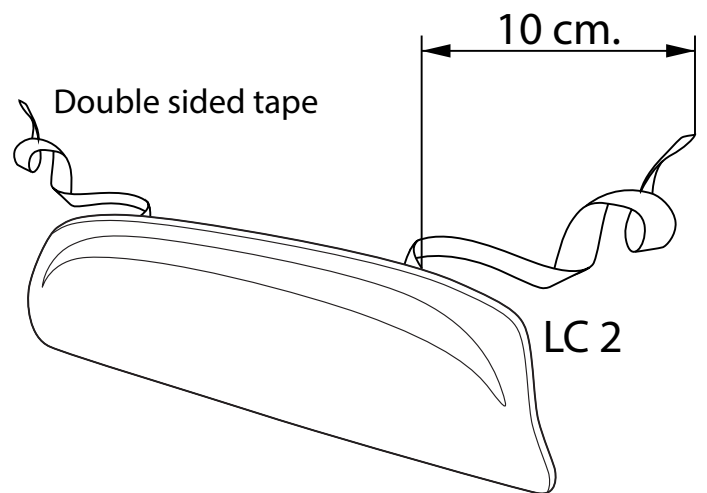

Take a new light cover sheet to peel tape off on both side, 10 cm. per side.

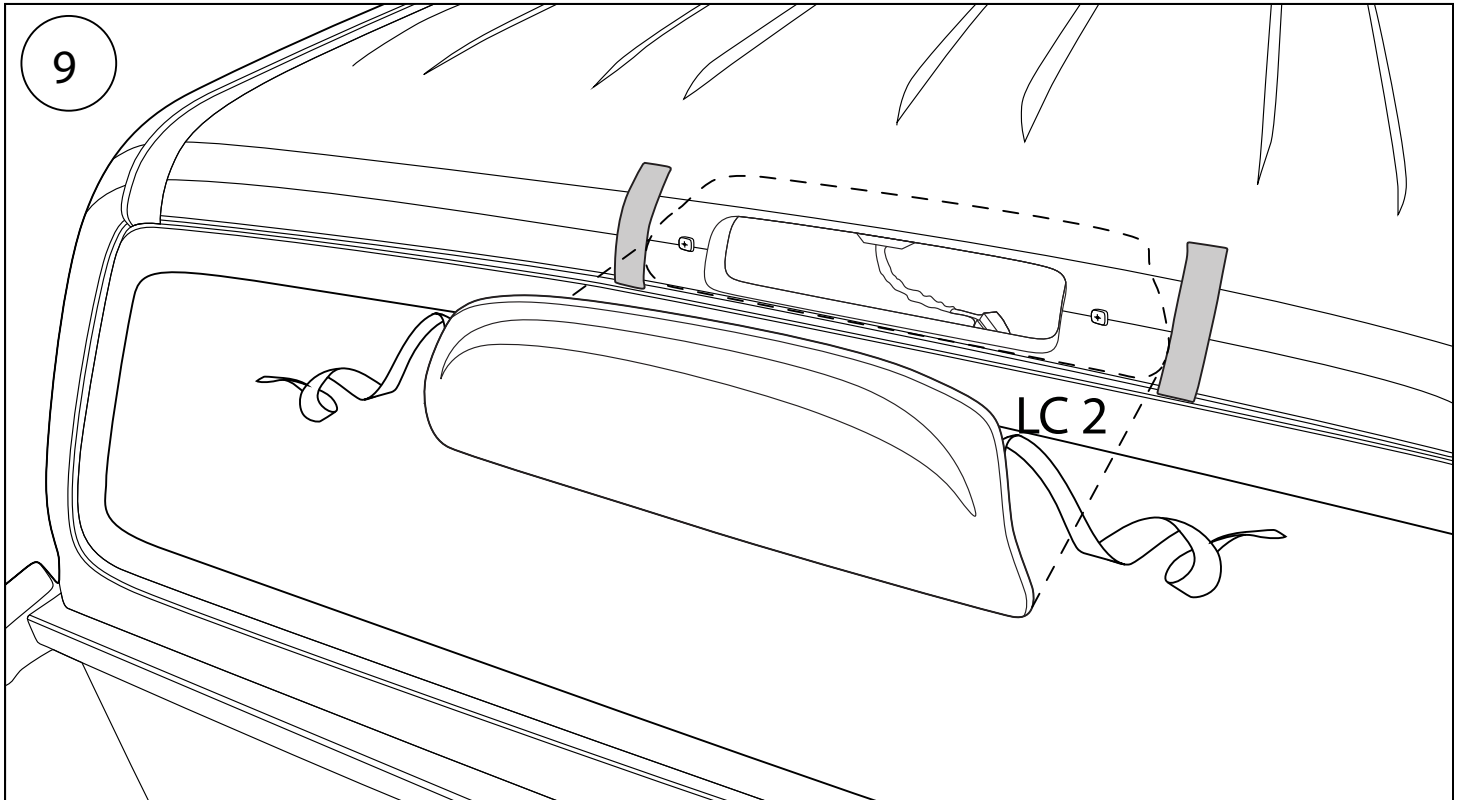

Then put a new light cover sheet over to measure a space compare to old mask line by using outer edge of light cover sheet must be in range between masking tape.

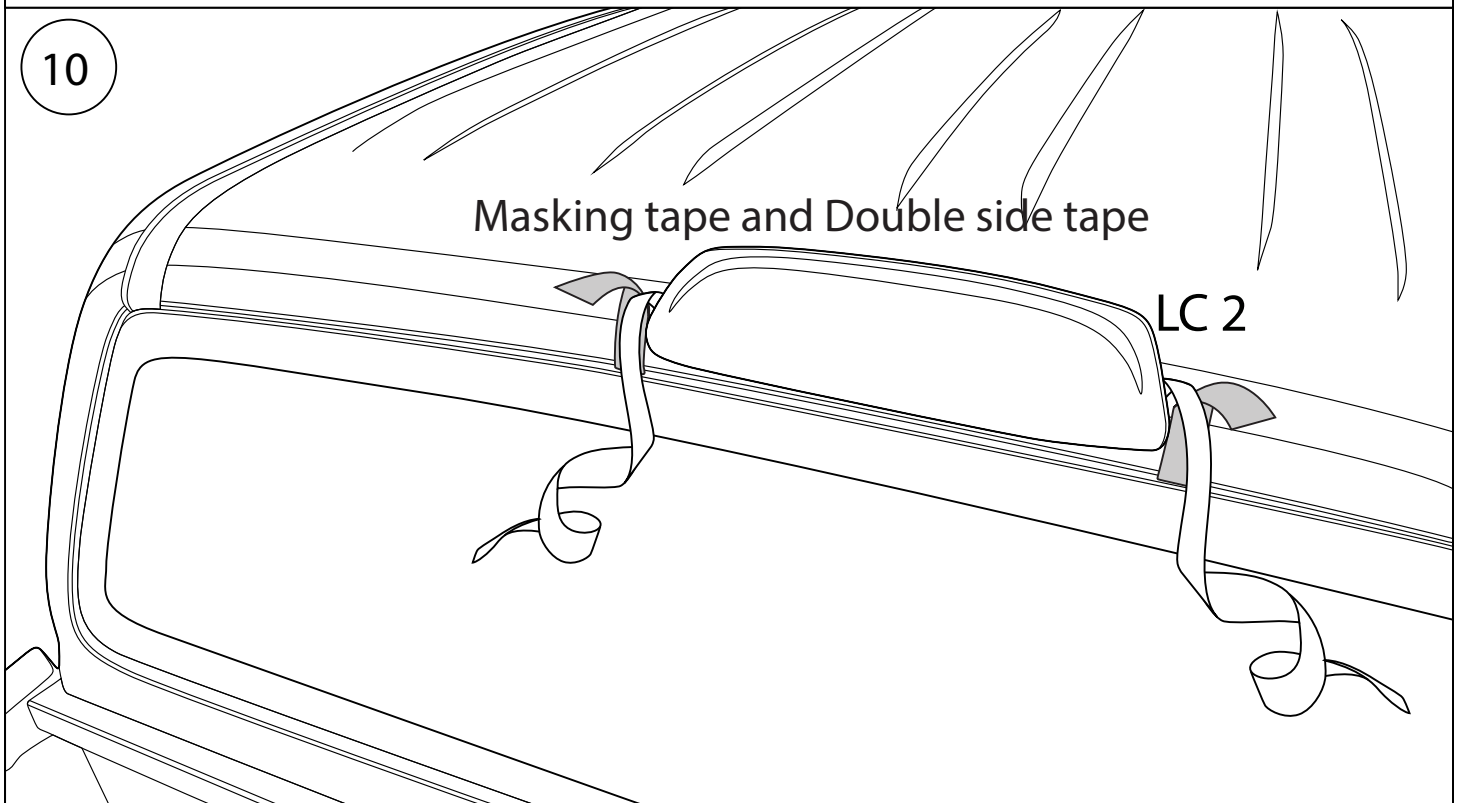





When got a space then peel all double sided tape off and peel masking tape out.



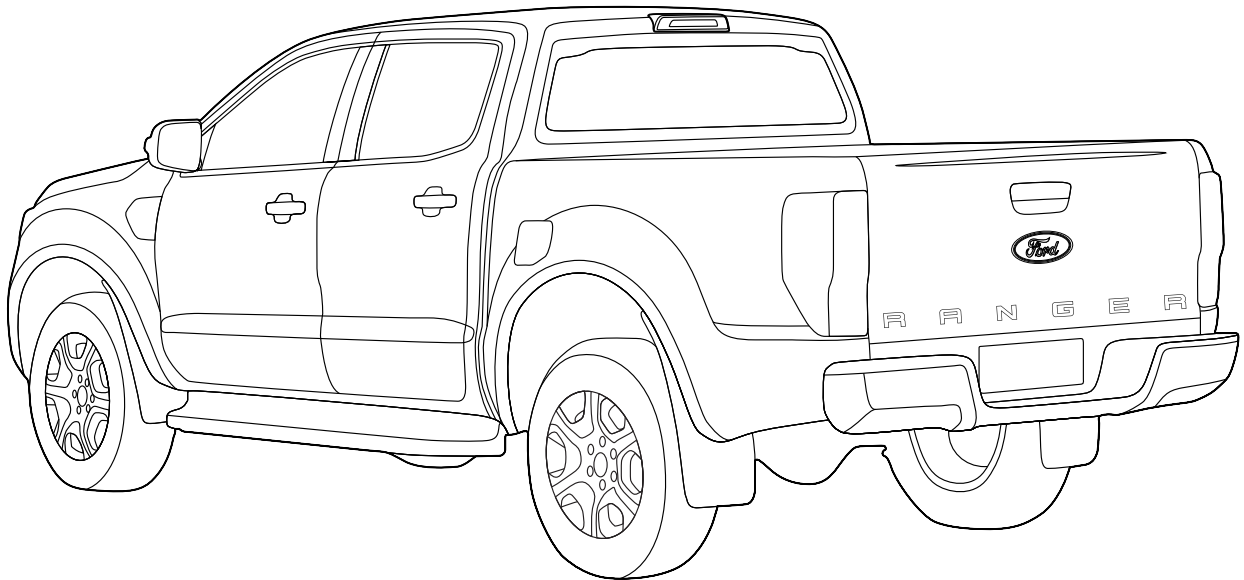

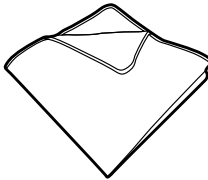
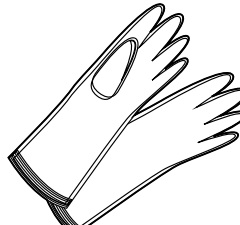

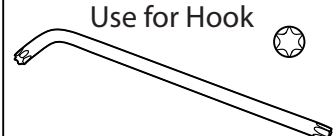

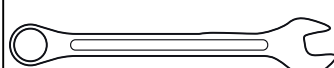

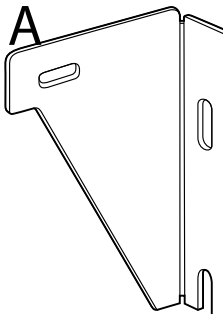
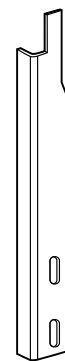



























Installation Manual

For Ford Ranger 2012



EQUIPMENT	TOOL
 <p>Fabric</p>  <p>Handcover</p>	 <p>No.10 Use for Bolt M6</p>  <p>Use for Hook Hexalobular Wrench # T40</p>  <p>Ruler</p>  <p>No.13 Use for Bolt M8</p>

SUPPORT ROOF SET	Bolt / Washer List																																				
 <p>A</p>  <p>B</p>	<table border="0"> <tr> <td></td> <td></td> <td><u>Bolt M8</u></td> <td></td> <td></td> <td><u>Bolt M6</u></td> </tr> <tr> <td></td> <td></td> <td>C : 8 pieces</td> <td></td> <td></td> <td>F : 2 pieces</td> </tr> <tr> <td></td> <td></td> <td><u>Spring Washer</u></td> <td></td> <td></td> <td><u>Spring Washer</u></td> </tr> <tr> <td></td> <td></td> <td>D : 8 pieces</td> <td></td> <td></td> <td>G : 2 pieces</td> </tr> <tr> <td></td> <td></td> <td><u>Washer</u></td> <td></td> <td></td> <td><u>Washer</u></td> </tr> <tr> <td></td> <td></td> <td>E : 8 pieces</td> <td></td> <td></td> <td>H : 2 pieces</td> </tr> </table>			<u>Bolt M8</u>			<u>Bolt M6</u>			C : 8 pieces			F : 2 pieces			<u>Spring Washer</u>			<u>Spring Washer</u>			D : 8 pieces			G : 2 pieces			<u>Washer</u>			<u>Washer</u>			E : 8 pieces			H : 2 pieces
		<u>Bolt M8</u>			<u>Bolt M6</u>																																
		C : 8 pieces			F : 2 pieces																																
		<u>Spring Washer</u>			<u>Spring Washer</u>																																
		D : 8 pieces			G : 2 pieces																																
		<u>Washer</u>			<u>Washer</u>																																
		E : 8 pieces			H : 2 pieces																																

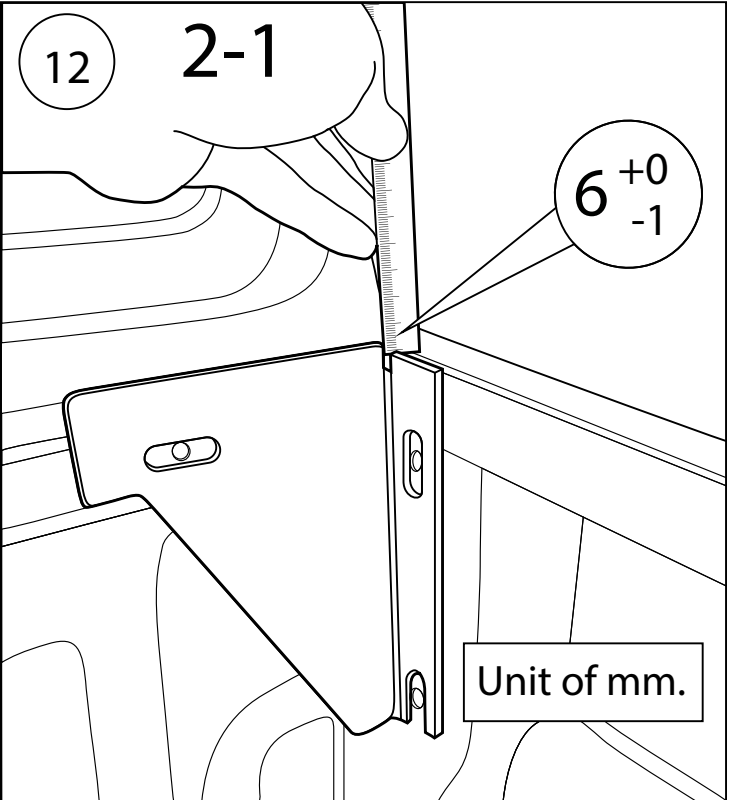
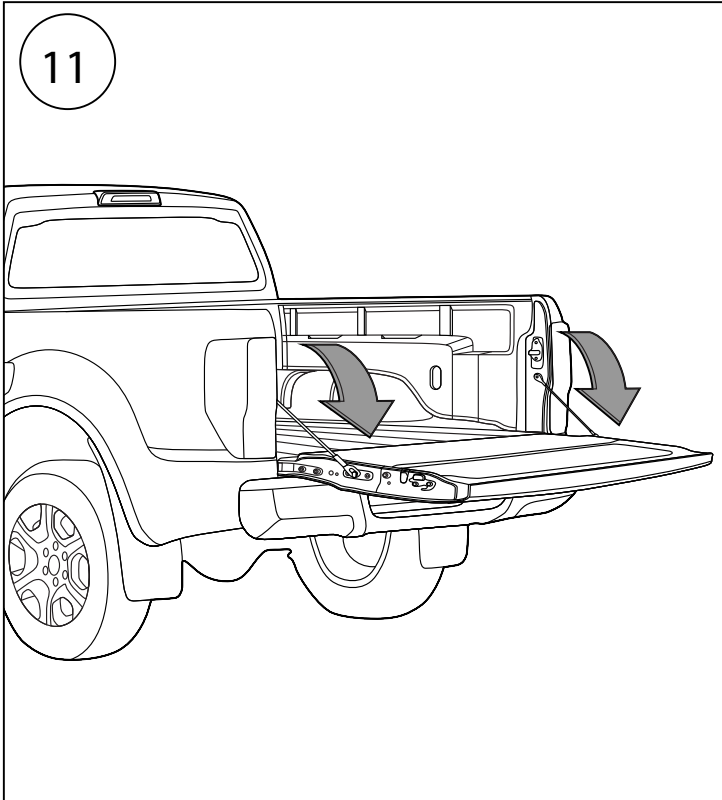

Open Tailgate

Check the Support Roof A must be 6 higher than edge of the tub. (RH)

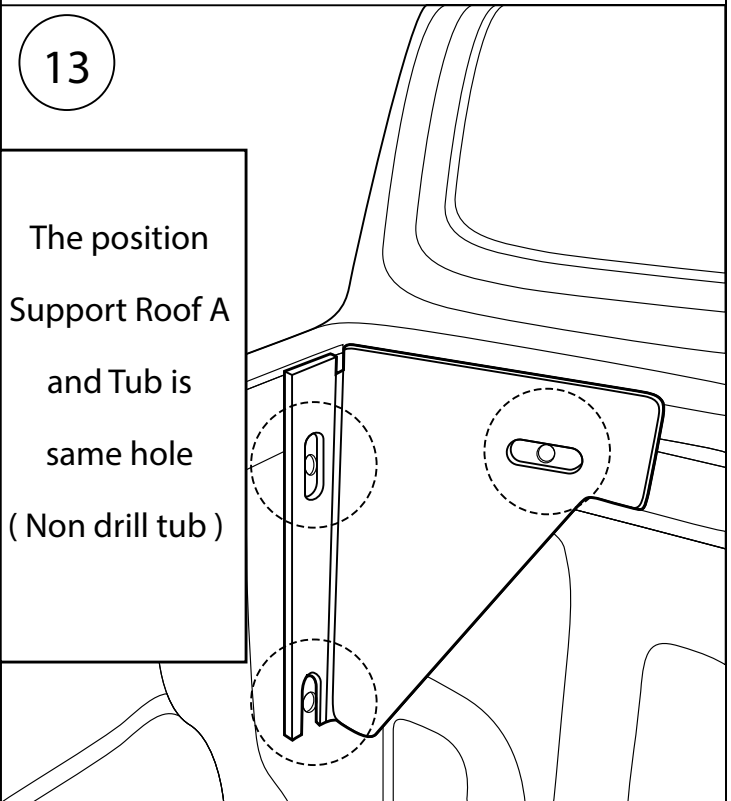
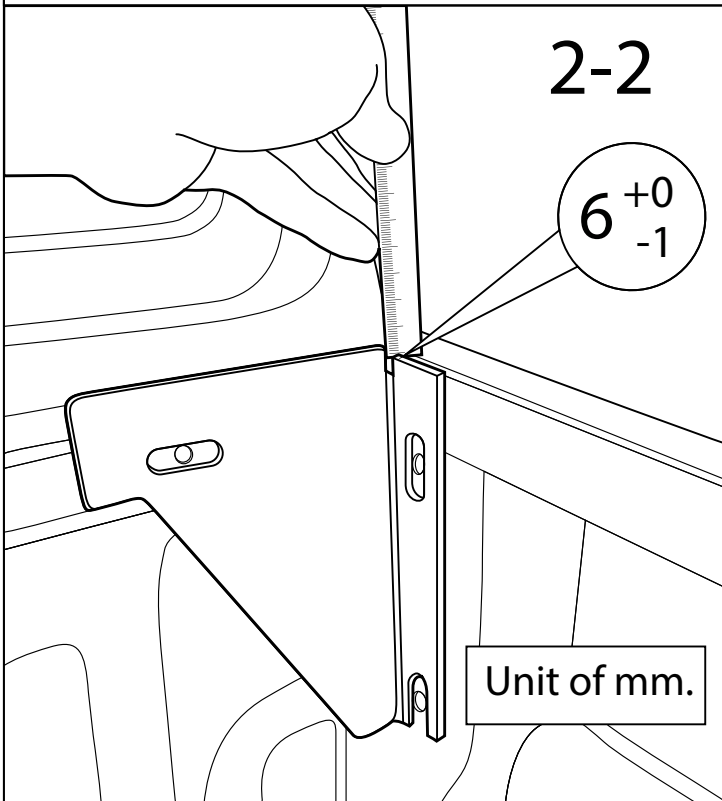

Check the Support Roof A must be 6 higher than edge of the tub. (LH)

The Support Roof A installtion must be reference in the hole position of the tub.

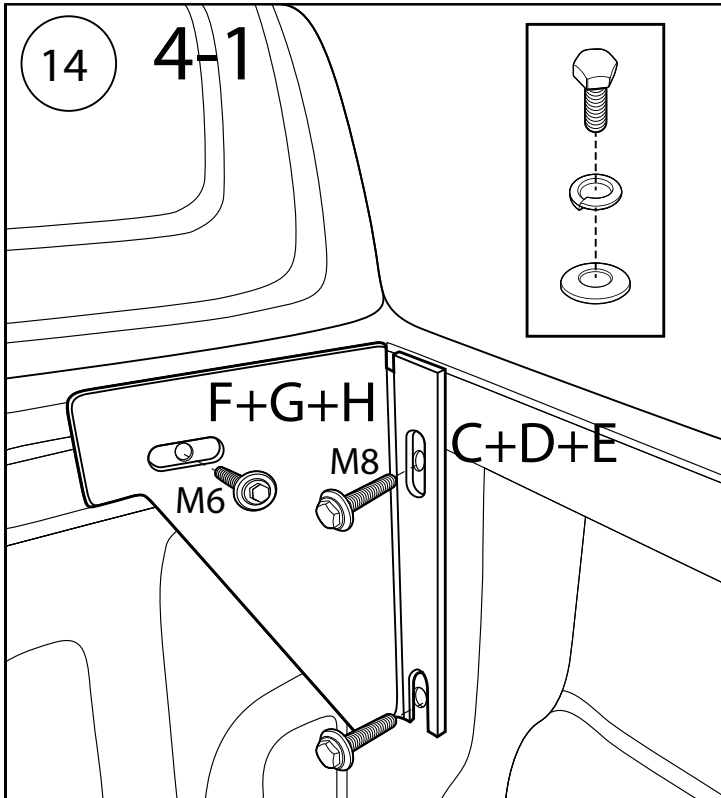

Install Support Roof A on the tub with bolt M6 and bolt M8 (RH)

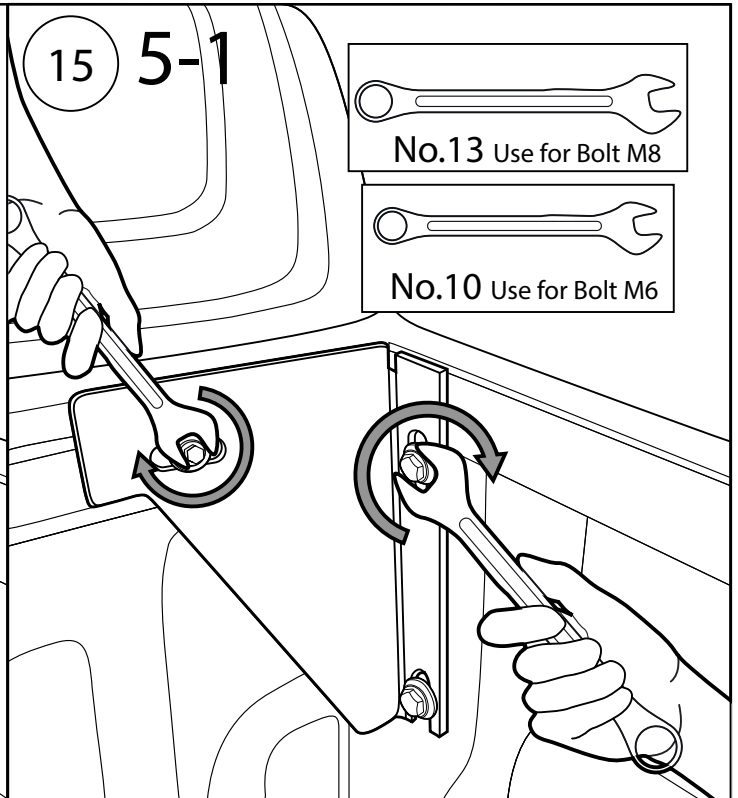

Tightening bolt M6 and bolt M8 by wrench

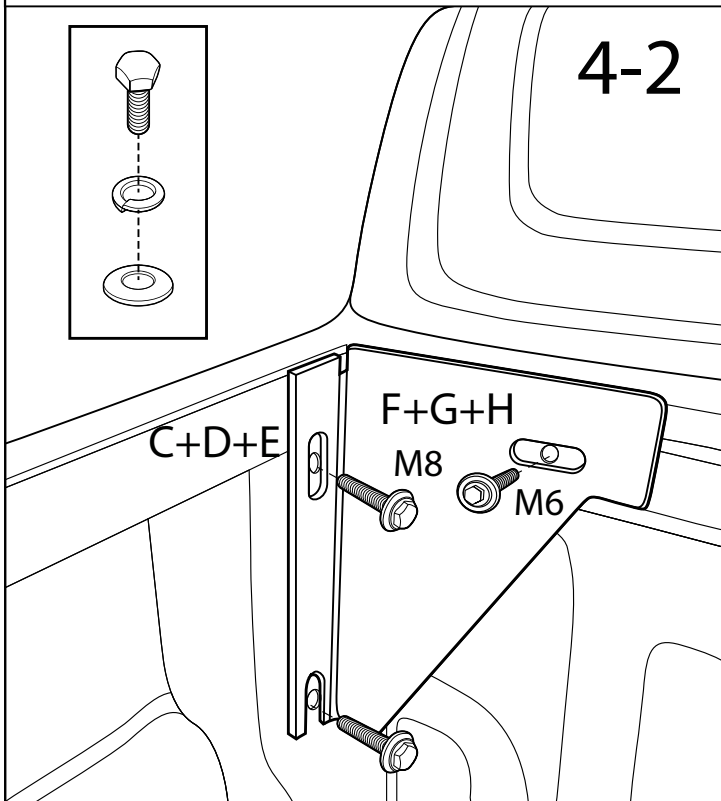

Install Support Roof A on the tub with bolt M6 and bolt M8 (LH)

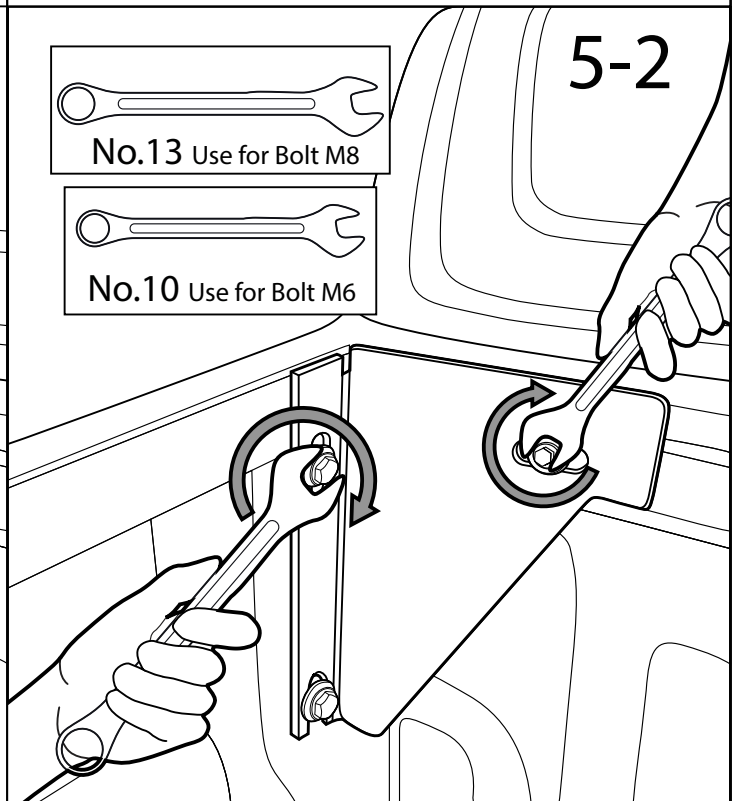

Tightening bolt M6 and bolt M8 by wrench



16

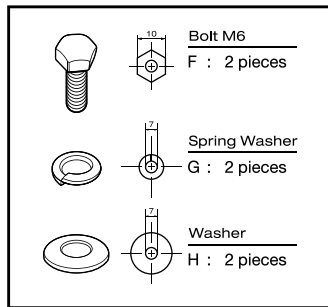

L / R = 2 pieces

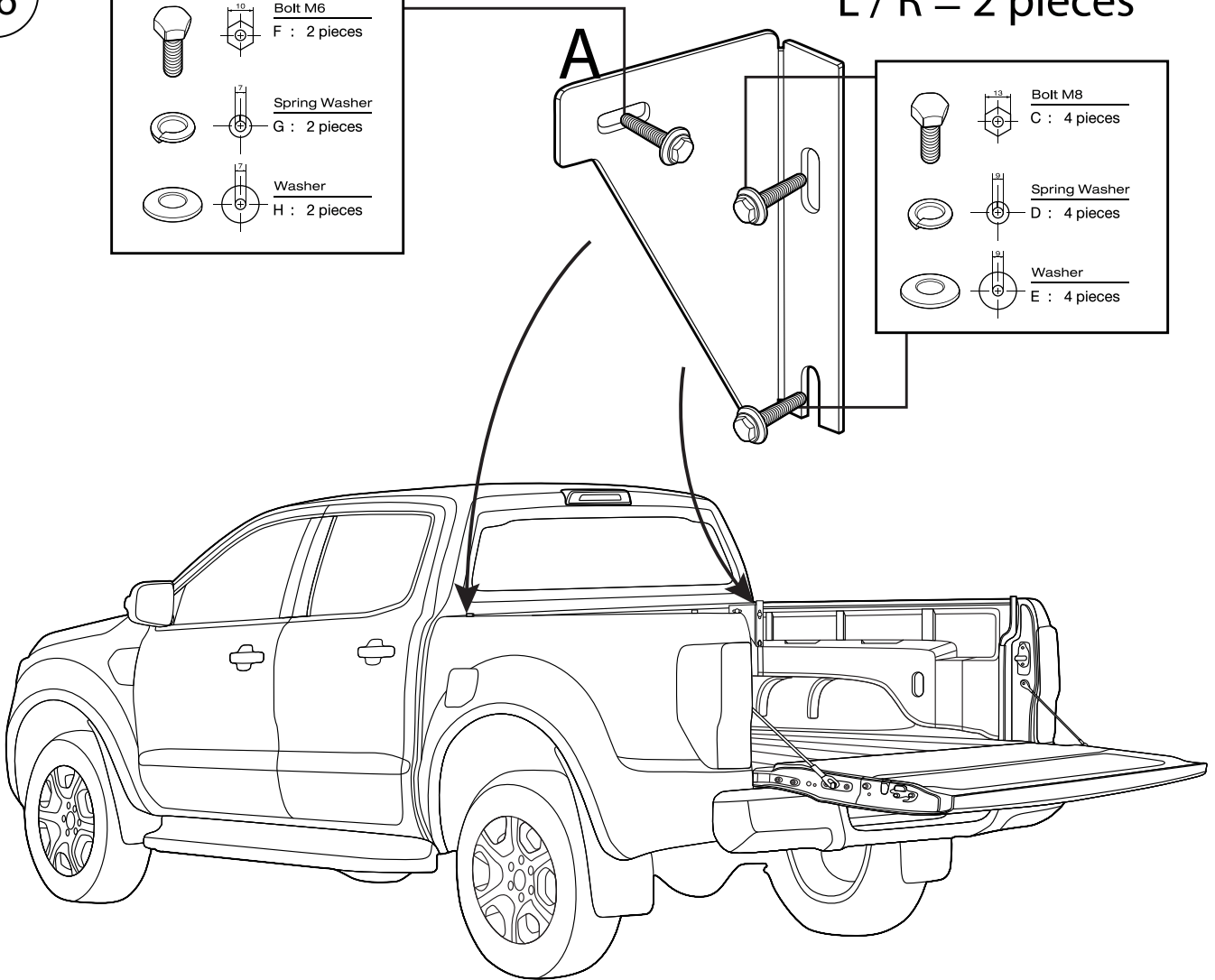
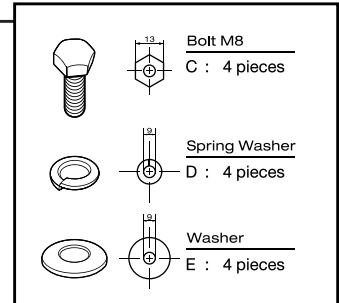

The installation locations for BRKT SUPPORT ROOF FR RH/LH and BRKT SUPPORT ROOF FR RH-LH on the tub.

Mechanical Installation Manual

All Models

Steel Canopy : S-Plus V2
Version 1.0

Part In Main Carton

P1: Steel Canopy S-Plus V2

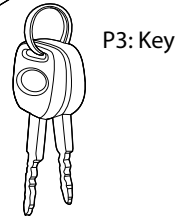
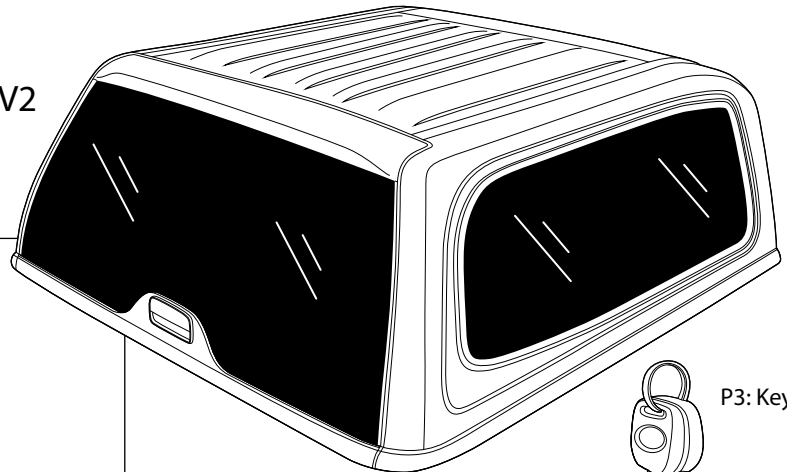

Kit Box

Part List Paper

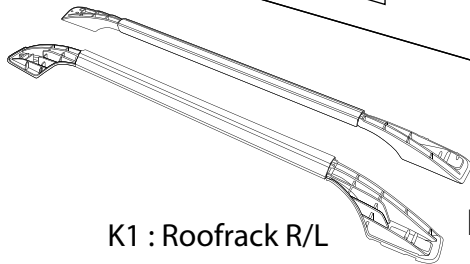
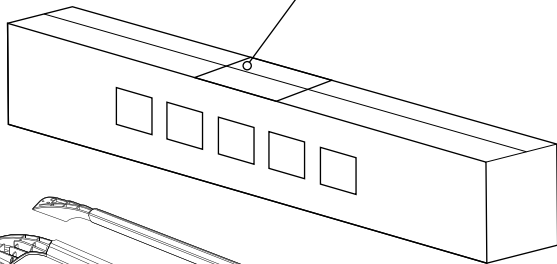

K1 : Roofrack R/L

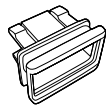

K3 : Switch Case



x4 (D-Cab)
x6 (C-Cab)

K5 : C-Clamp

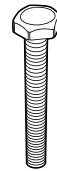

x8

K7 : Bolt M6



x8

K9 : Washer M6



x8

K10 : Washer M8

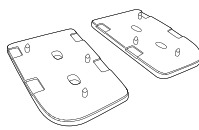

x2

K2 : Rubber R/L

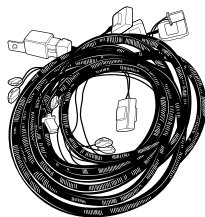

K4 : Wiring No.38

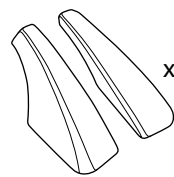

x2

K6 : Roofrack Cover

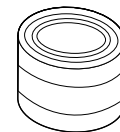

K8 : T Paint

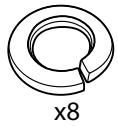

x8

K11 : Spring Washer M6

Require Tools



T1 : 13 mm. Wrench

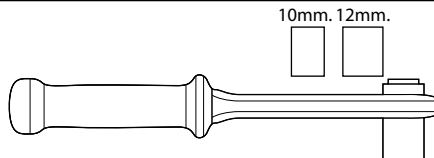

T3 : 10,12mm. Torque Wrench

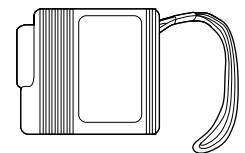

T4 : Measuring Tape/Ruler

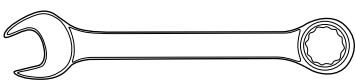

T2 : 10 mm. Wrench

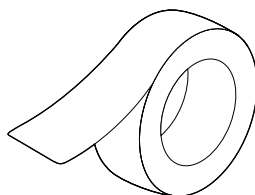

T5 : Tape

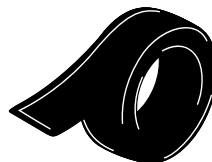

T6 : Electric Tape

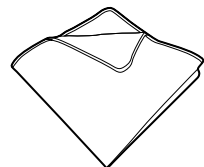

T7 : Fabric

17

The Procedure of checking the Sammitr canopy box before installation.

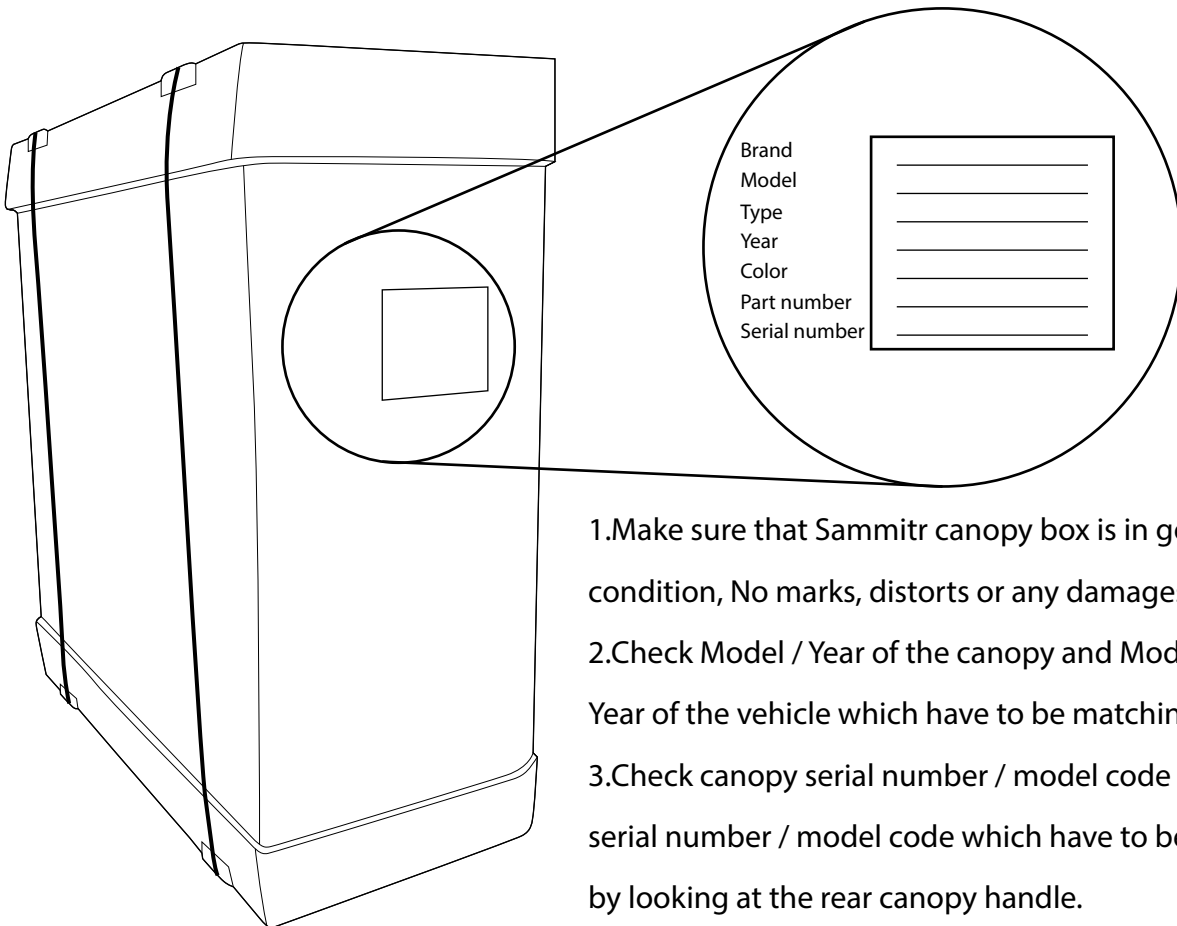

1. Make sure that Sammitr canopy box is in good condition, No marks, distorts or any damages.
2. Check Model / Year of the canopy and Model / Year of the vehicle which have to be matching.
3. Check canopy serial number / model code and vehicle serial number / model code which have to be matching by looking at the rear canopy handle.

4. Check all the accessories received inside the box with the Packing List.

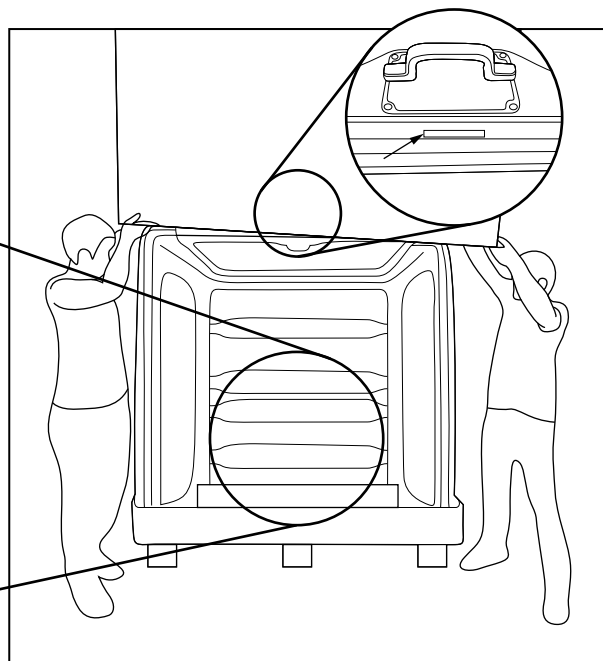
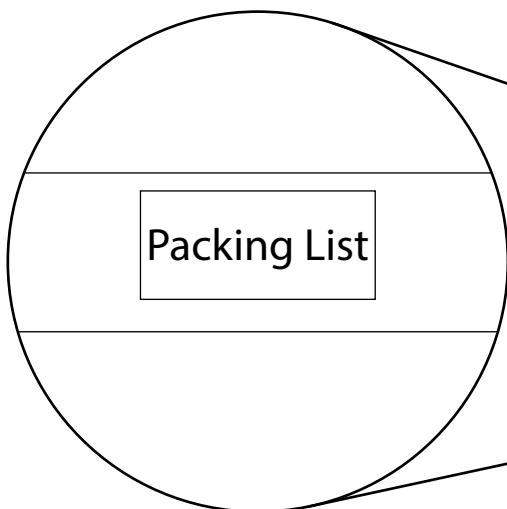



18 The preparation process of Sammitr Canopy TL-1 model before installation with the vehicle.

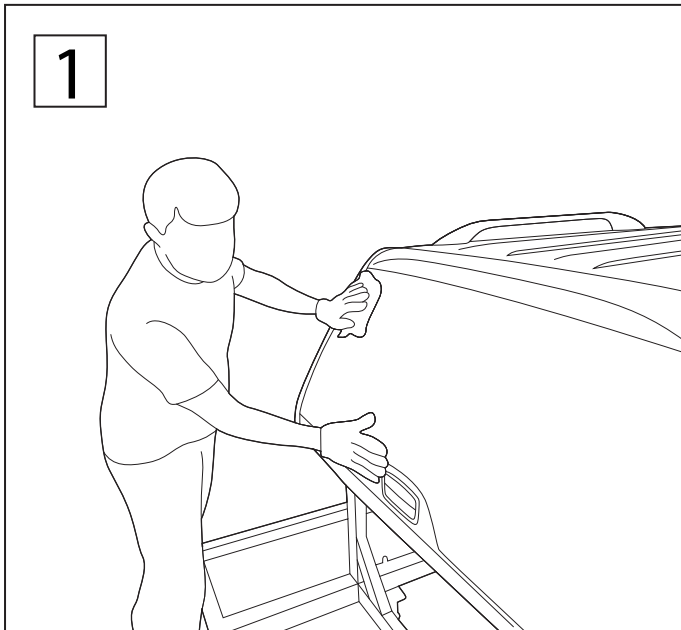

1. Canopy have to be in good condition, no damage, dent, cracks, smooth surface including no window damages or cracks.
2. Locking system is working for both keys.
3. Canopy sides are not damage, dent or cracks.
4. Canopy front window panel is working (open/close), no cracks or damages occurrences.
5. Check the Rear Door by open and close.

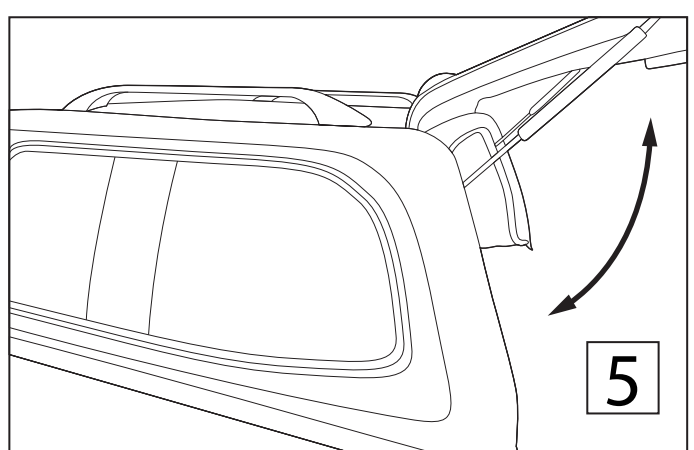
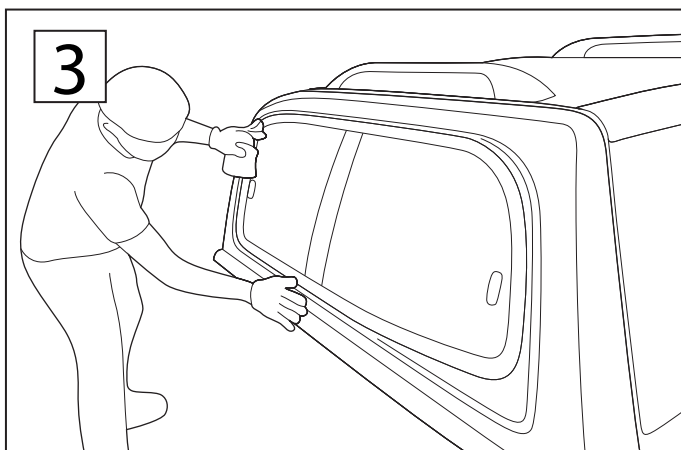
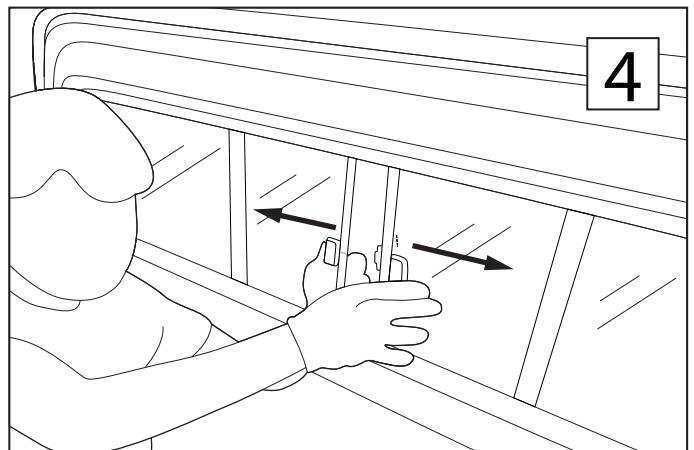
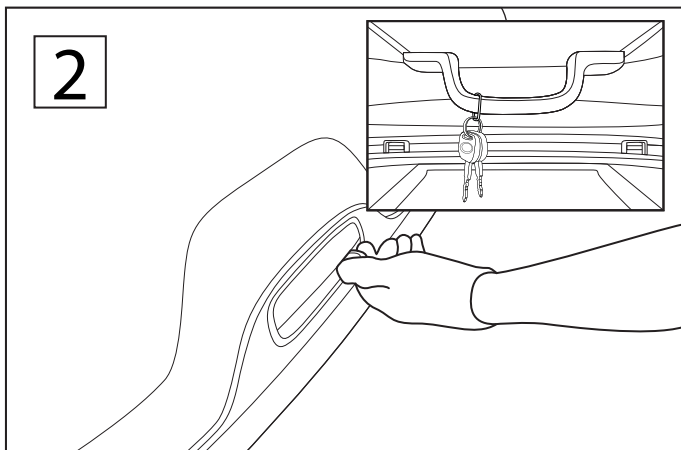

- 19) The process of Roof rack installation manual of the S-Plus V2 canopy before installs on the vehicle.

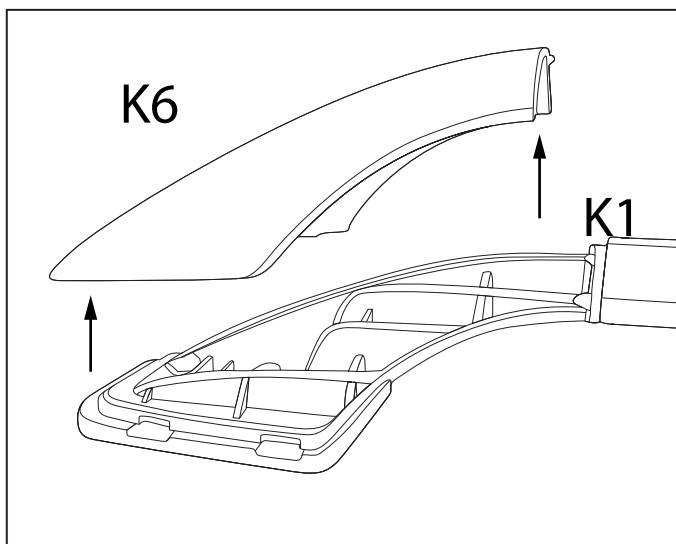
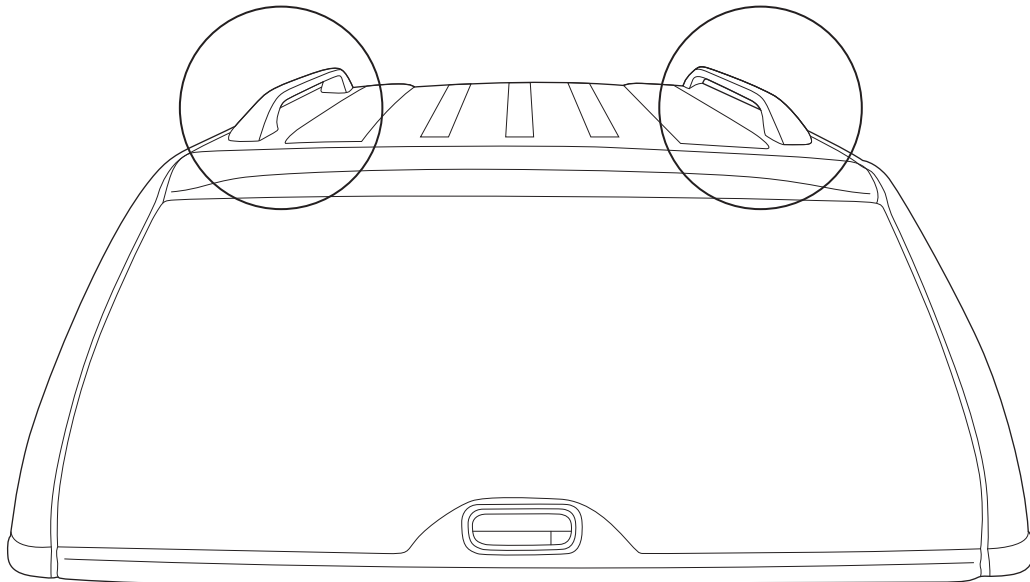

Roof rack Front Part
Rear Left

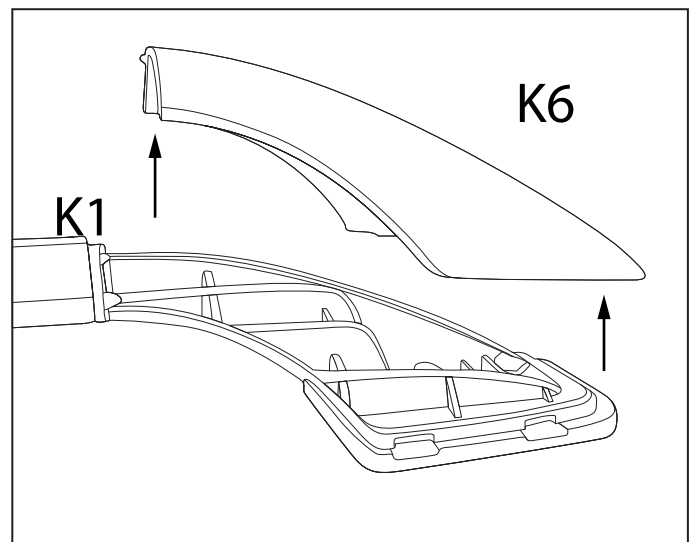

The process of remove the roof rack cover on the S-Plus V2 canopy in order to install nuts.



20

Roof rack Front part – Rear Right.

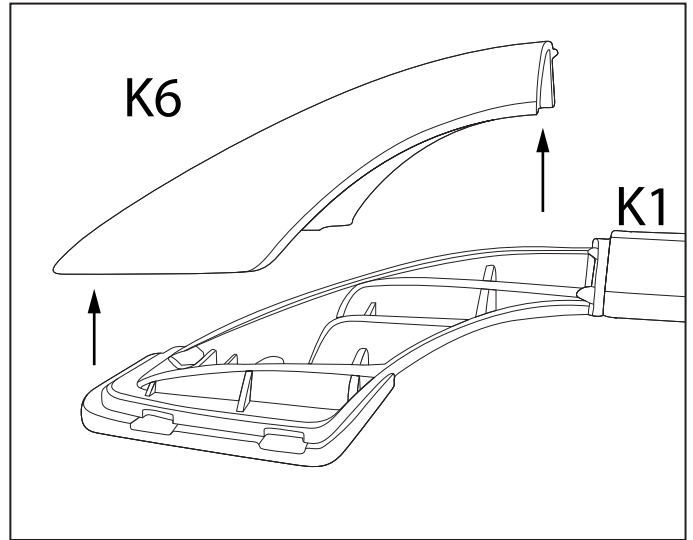
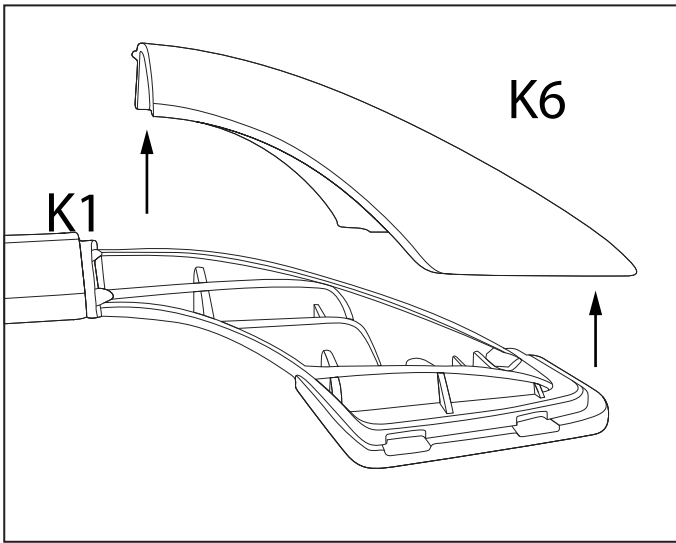

The process of remove the roof rack cover on the S-Plus V2 canopy in order to install nuts.

21

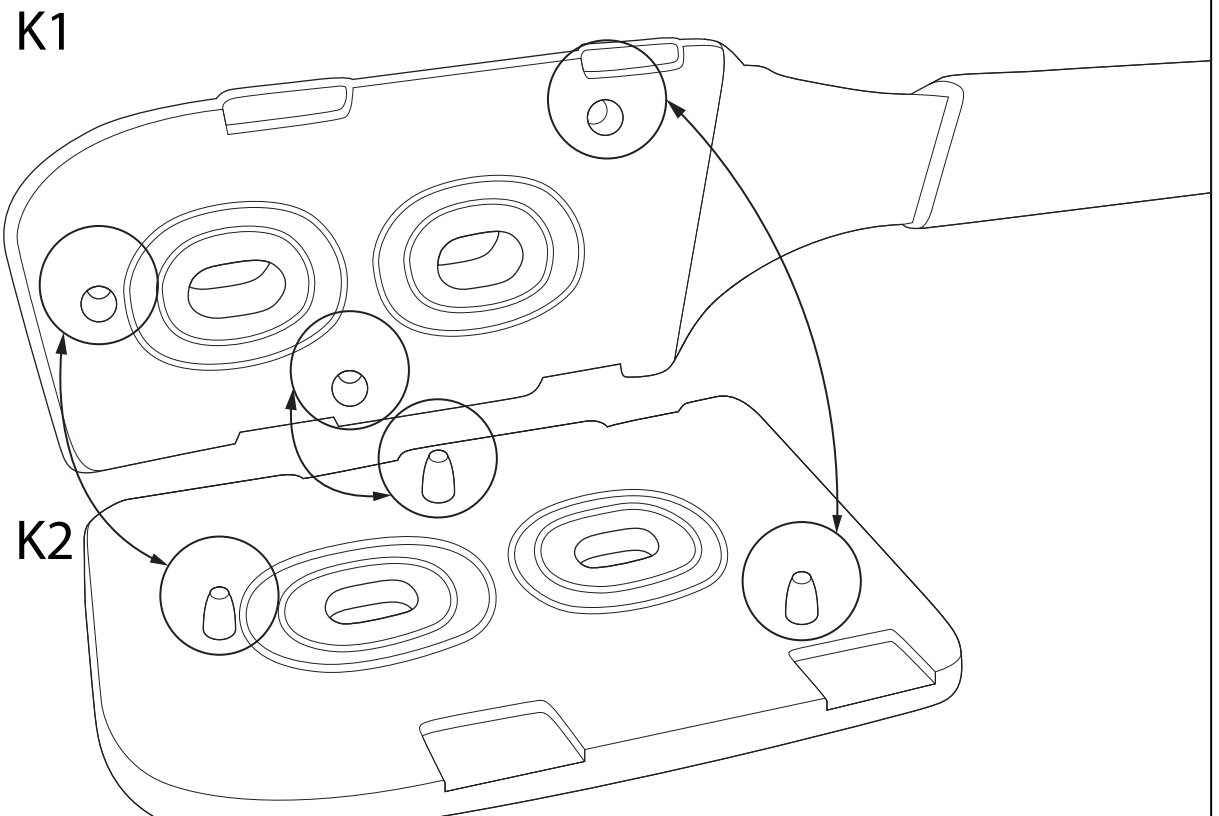

Rubber Pad dispatch position of the Roof rack legs when install on the canopy.

Bolt M6

K7

Washer M6

K9

Spring Washer M6

K11

Bolt M8

K10

Roofrack

K1

Rubber Pad

K2

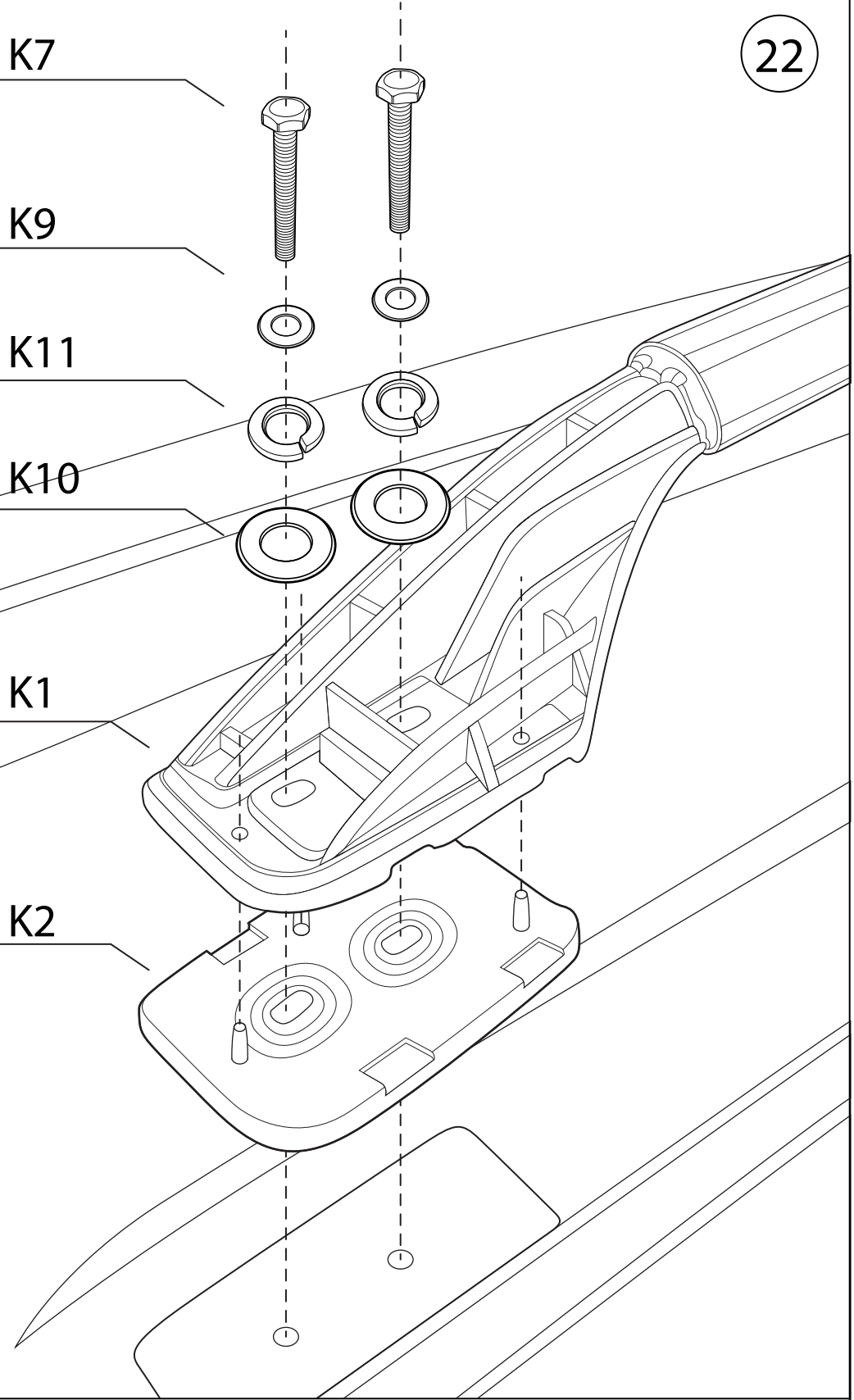

The process/step of install Roof rack accessories on the S-Plus V2 canopy, all 4 points.

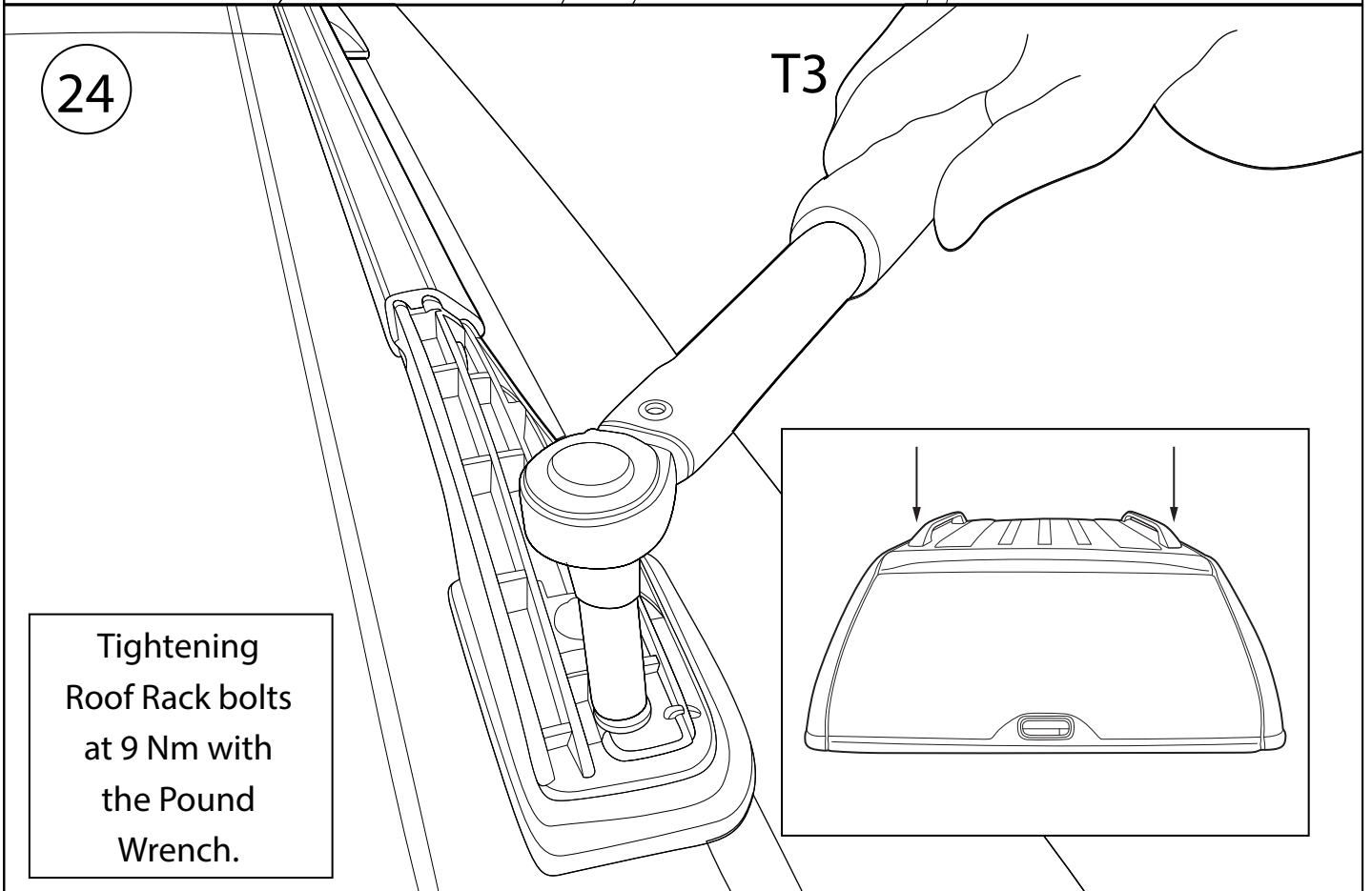
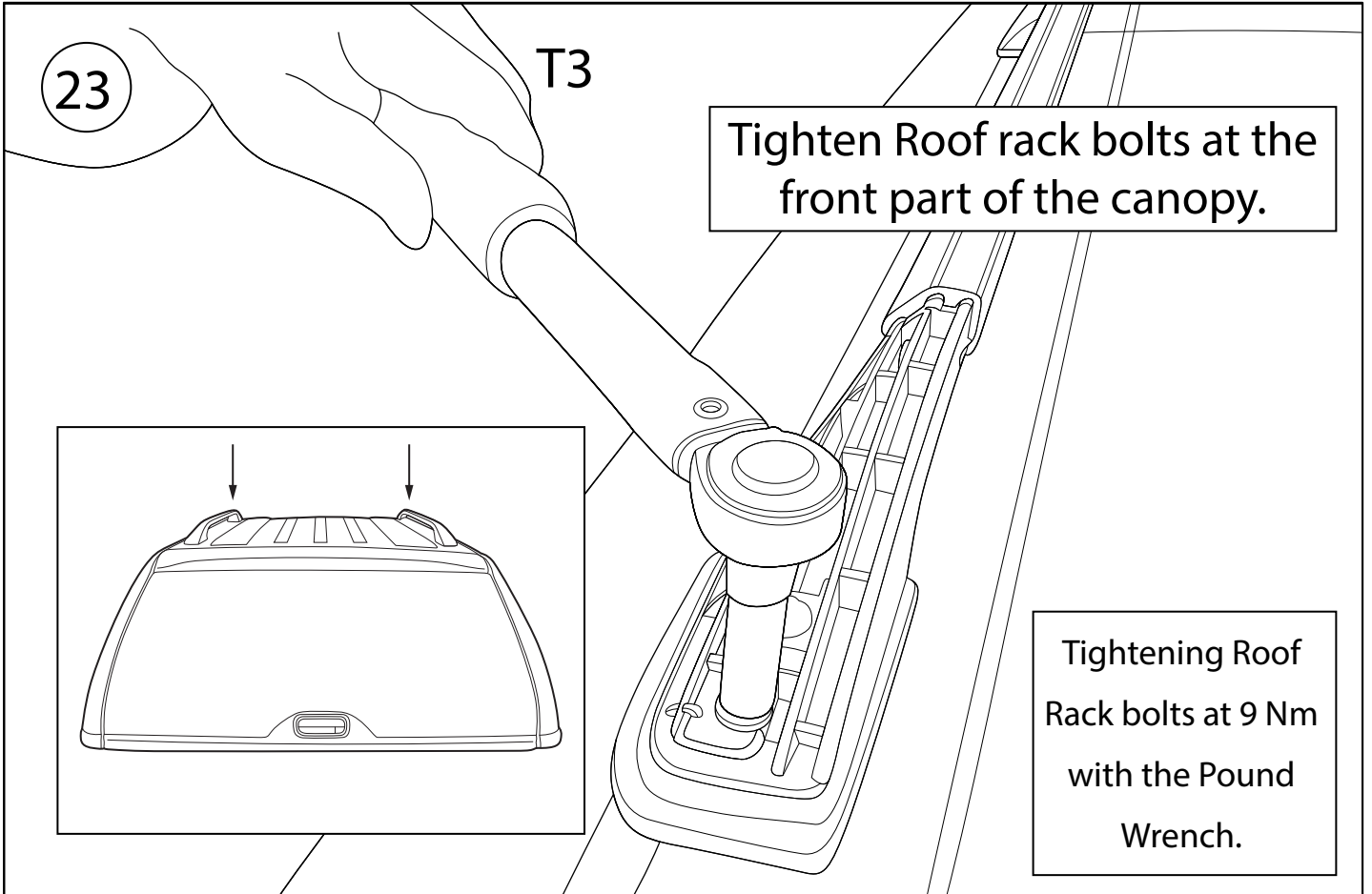

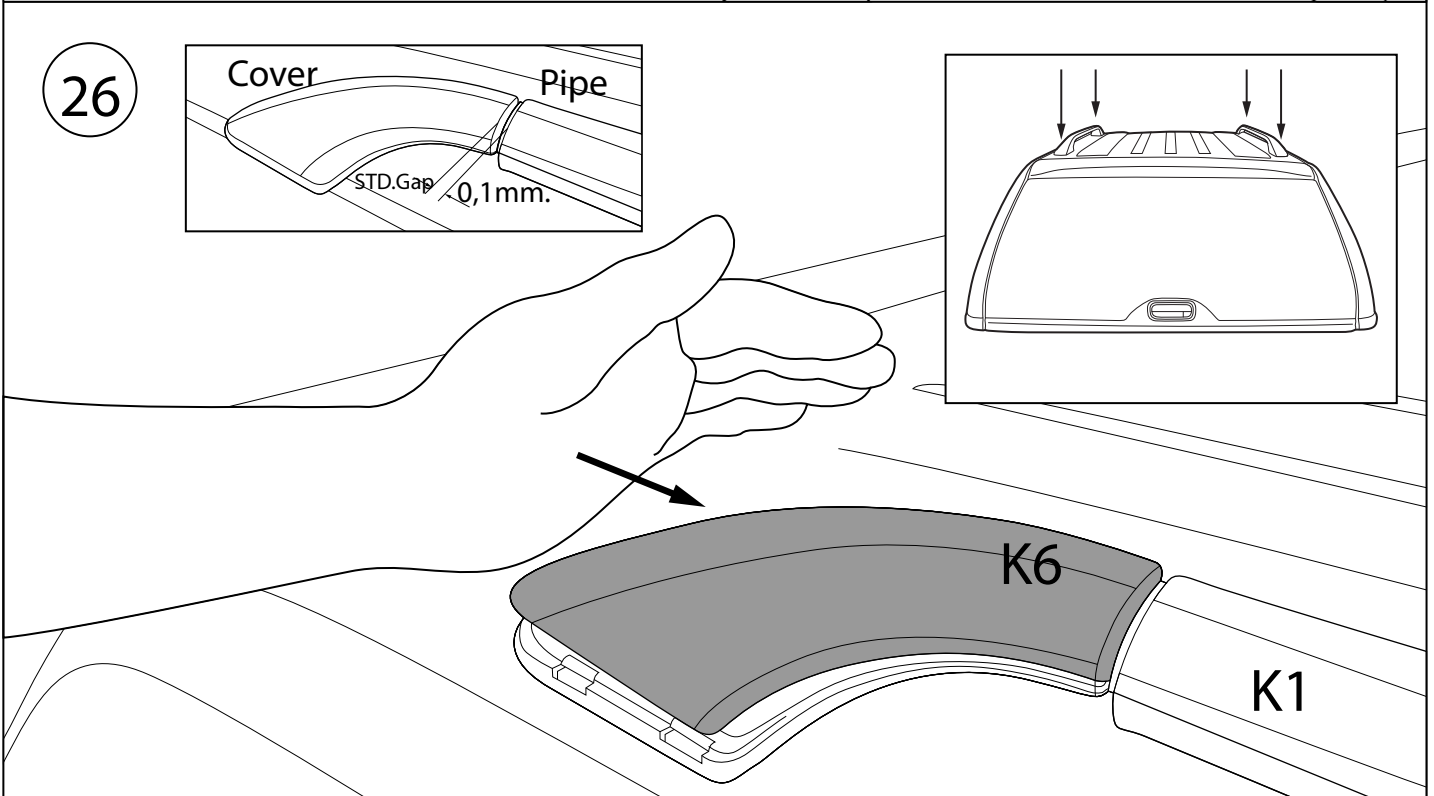
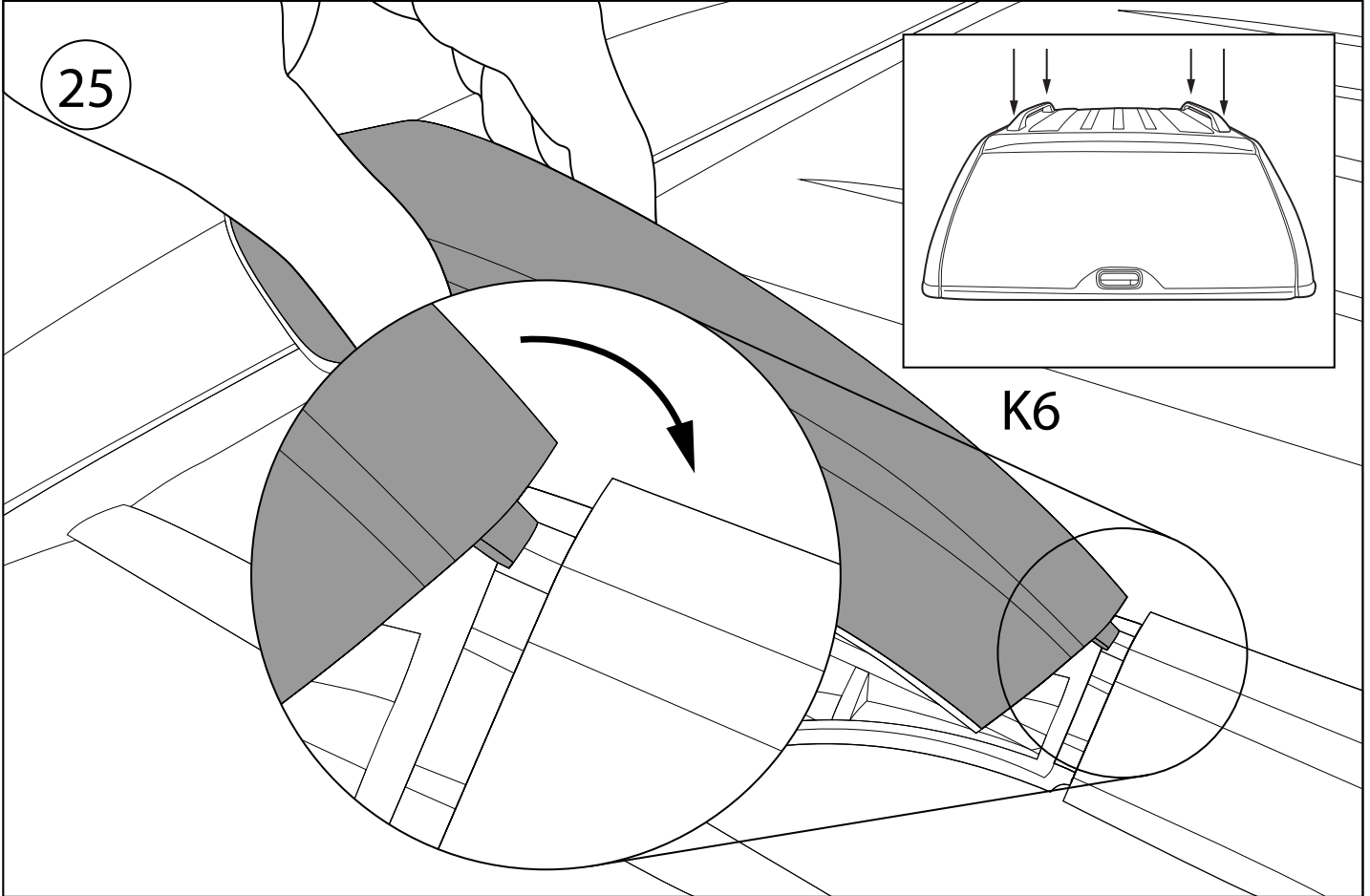

Press and push the Roof rack cover back to the position by hand, then check the gap between cover and roof rack (pipe)

27 The process of checking and preparing the Nissan Navara vehicle before install the canopy

1. Clean up the vehicle body including the top, all sides and Rear tub.
2. Cover the fabric to protect the scratches resistant.

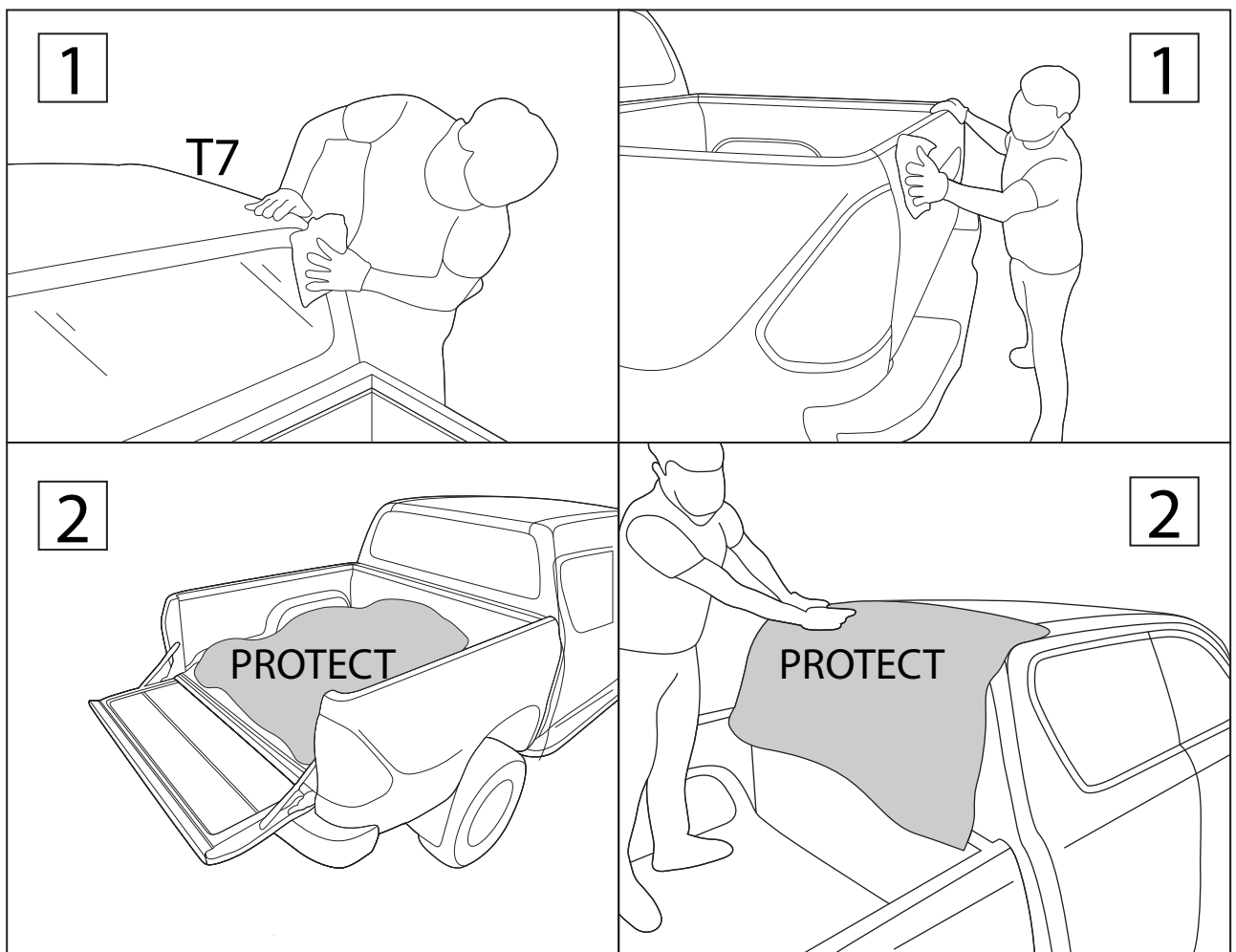



28 The process of preparing Sammitr Canopy S-Plus V2 model before install on the vehicle.

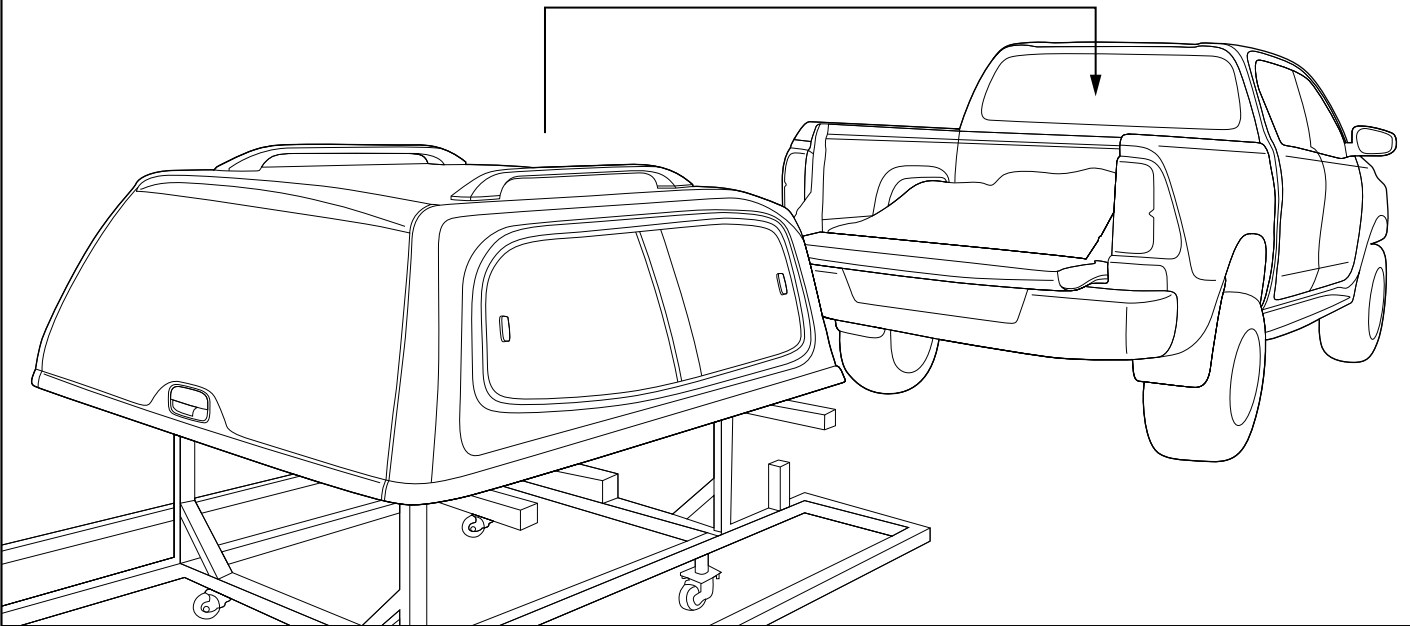

29

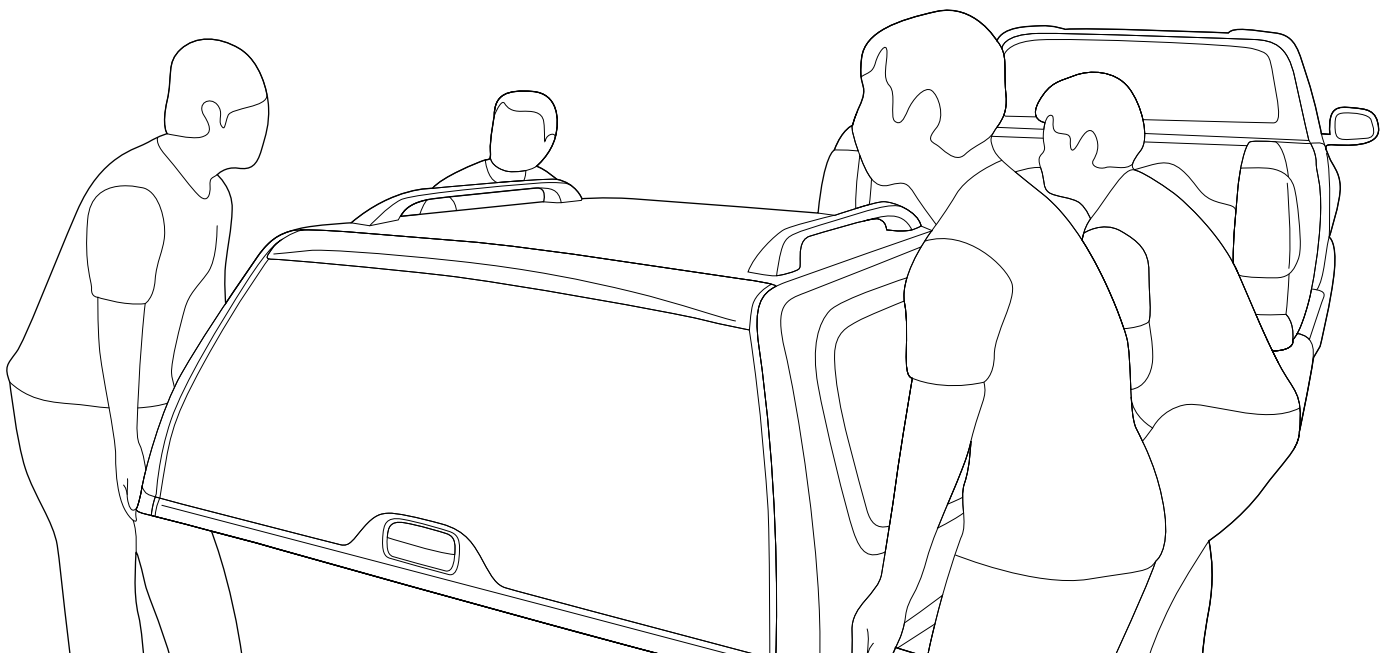

The process of lifting the canopy onto the vehicle tub by using 4 people for lifting.

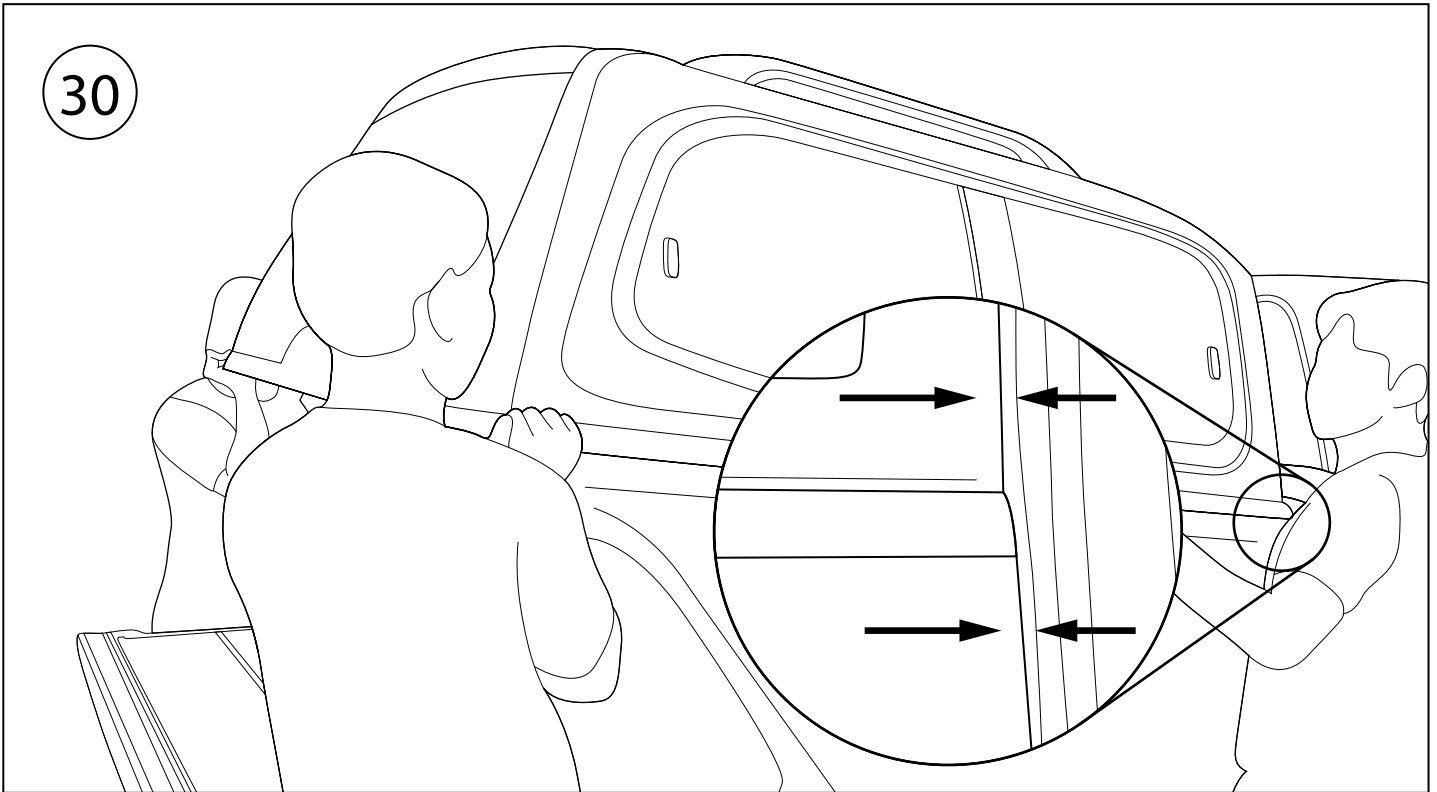

Lift canopy over the pick up truck by rising the rear part higher and the front part to be in the parallel with the edge of the vehicle tub.

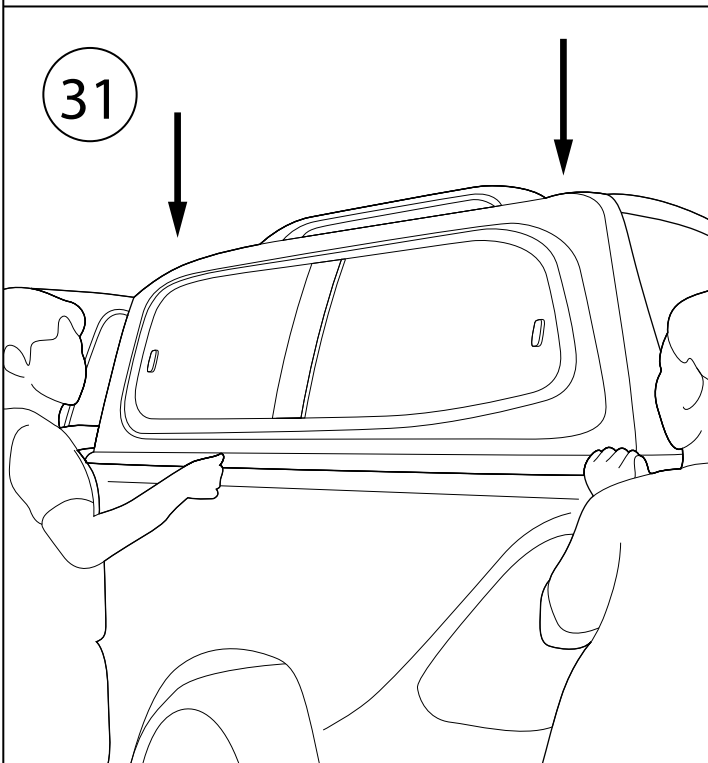

After get the distance in front part and then put the rear part to cover the vehicle tub.

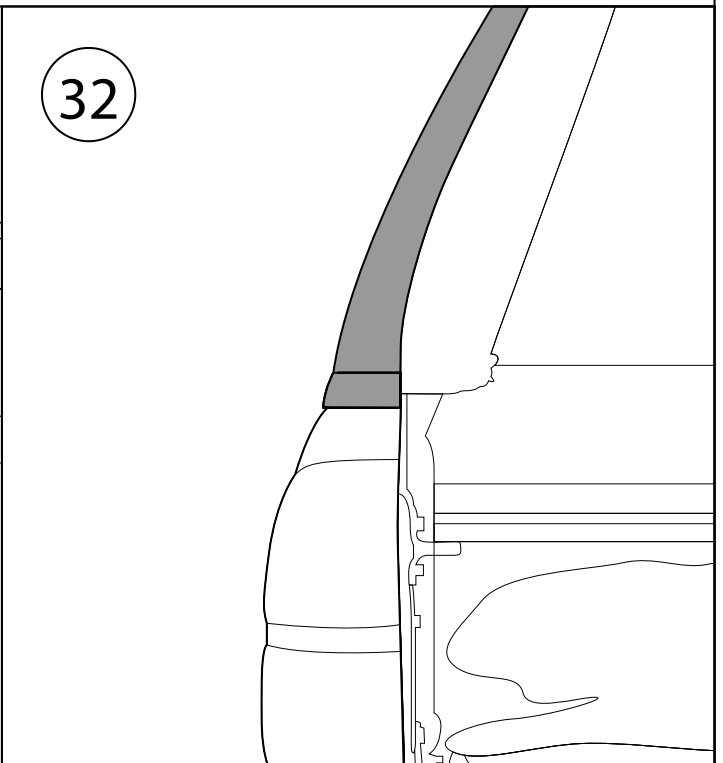

Check gap between canopy and vehicle tub have to be the same for both left and right sides.

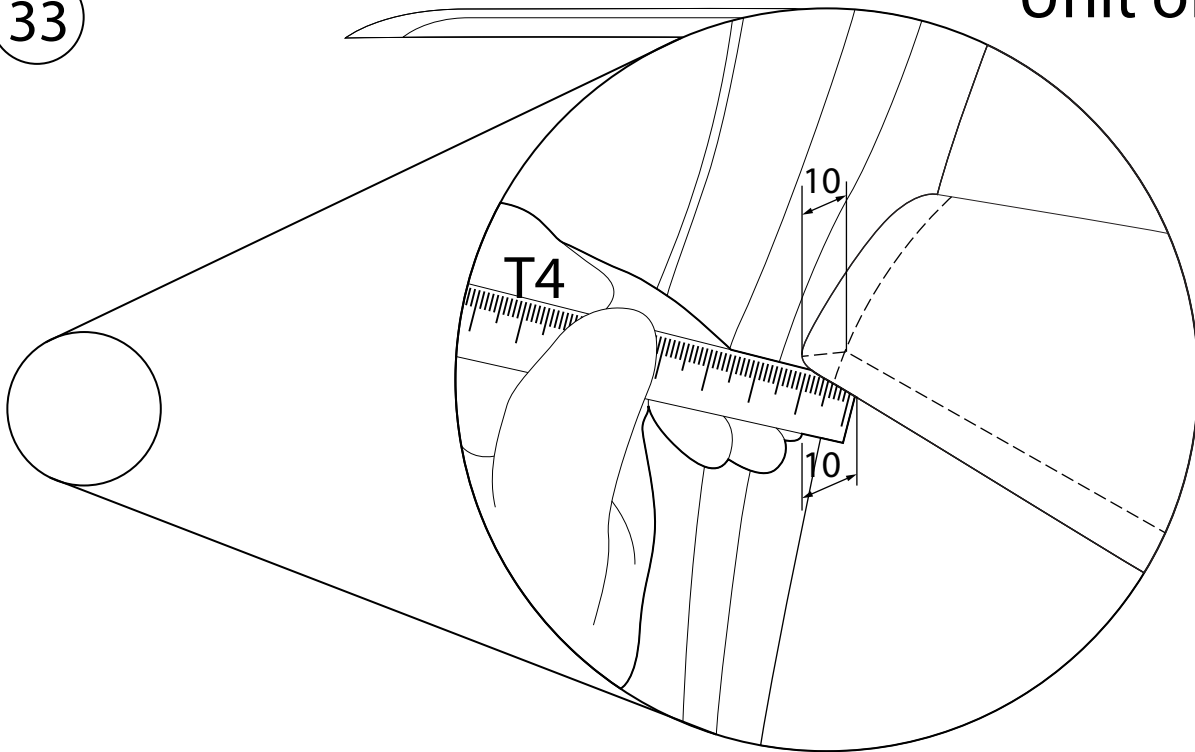
33**Unit of mm.**

Measure the distance between canopy coverrail and the vehicle, to have the 10mm distance in overall.

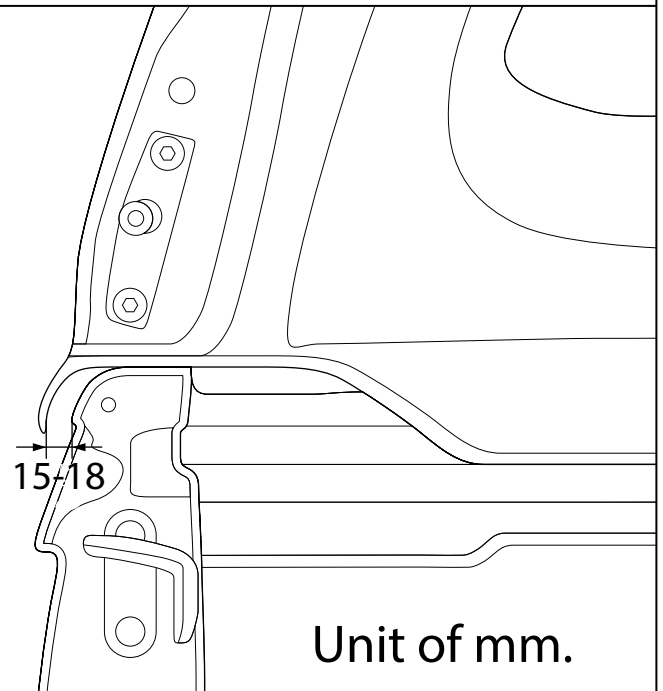
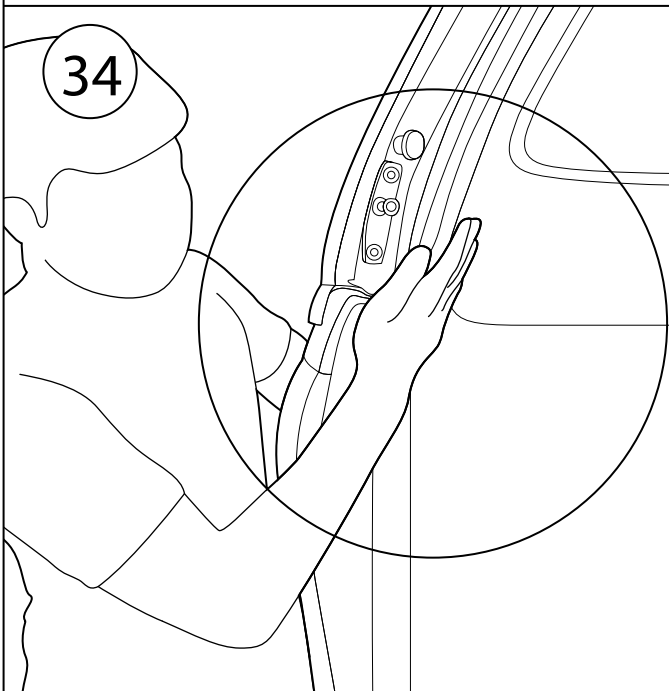
34**Unit of mm.**

After finished measure the front part, check the distance at rear part of canopy which must have the distance of 15mm.



35 The process of C-Clamp installation
S-Plus V2 canopy model with the vehicle.

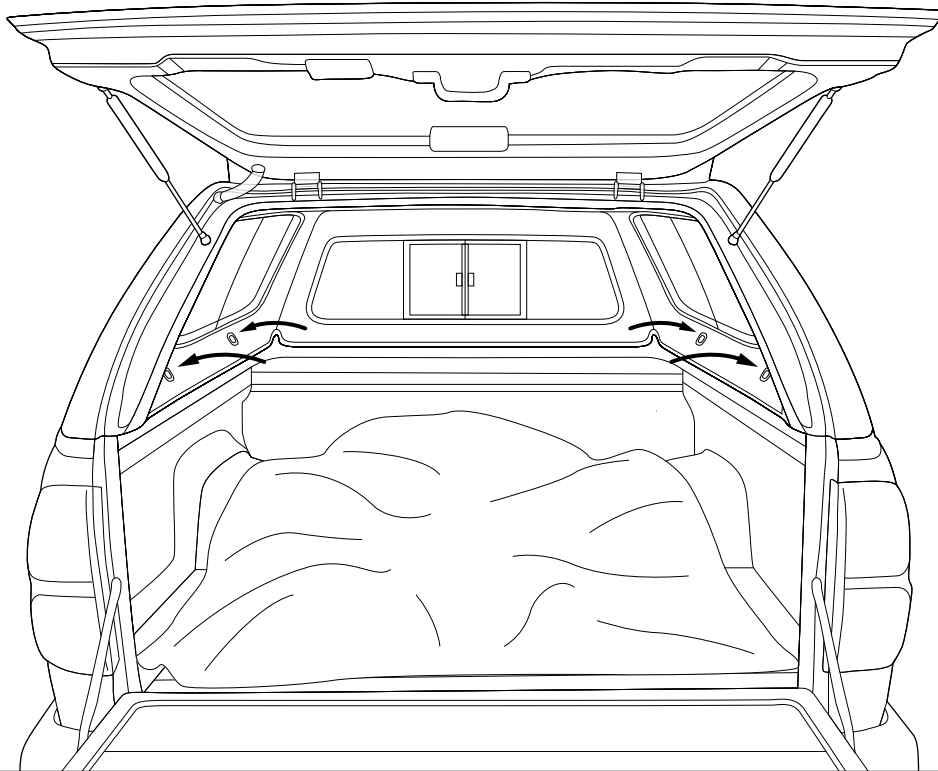

36

Open / take
off the rubber plug.

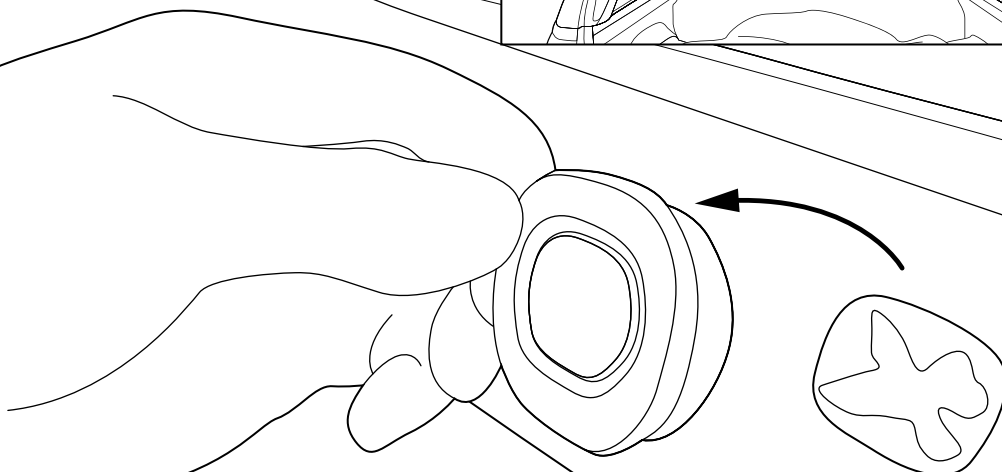
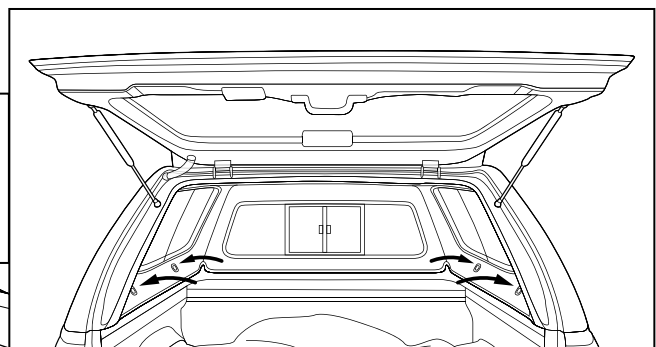



37

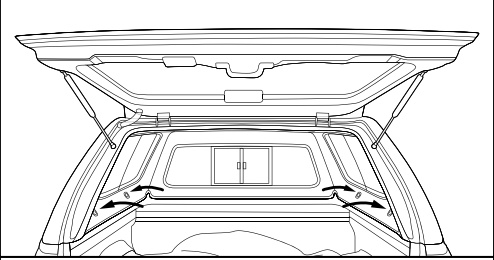
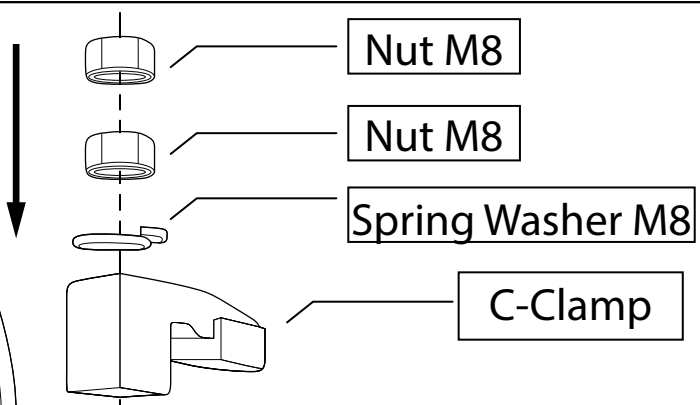

The process of C-Clamp installation onto the vehicle tub, all 4 positions.

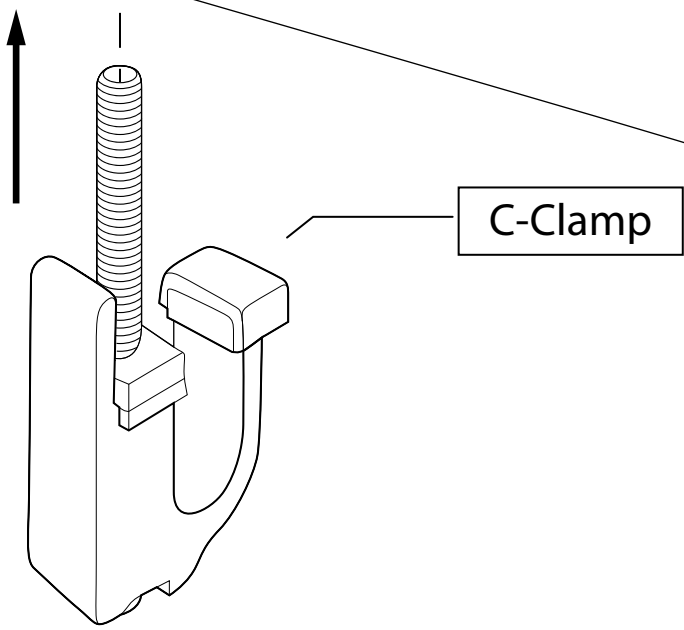



38

Tighten bolts of c-clamp by using pound wrench, with the pressure of 16 Nm.

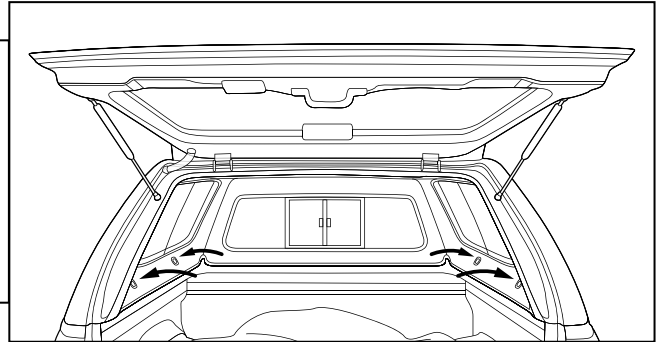

T3

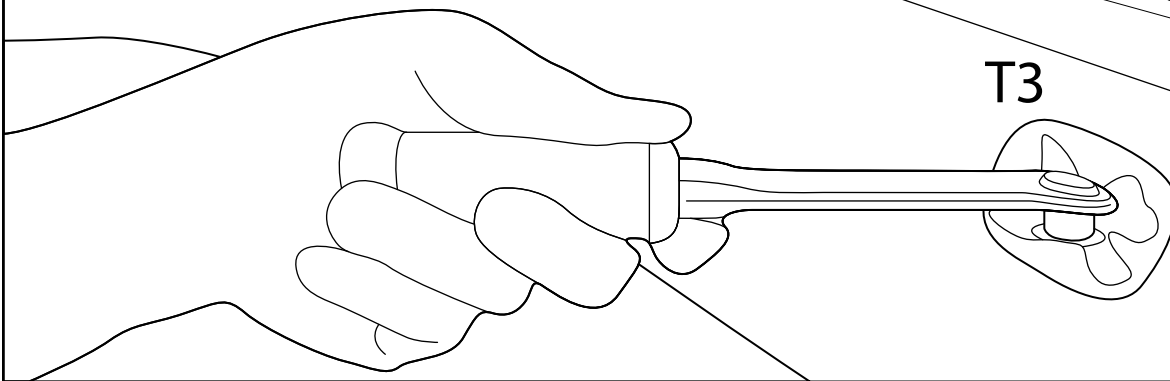

Tighten canopy C-Clamp bolts with vehicle all 4 positons.

39

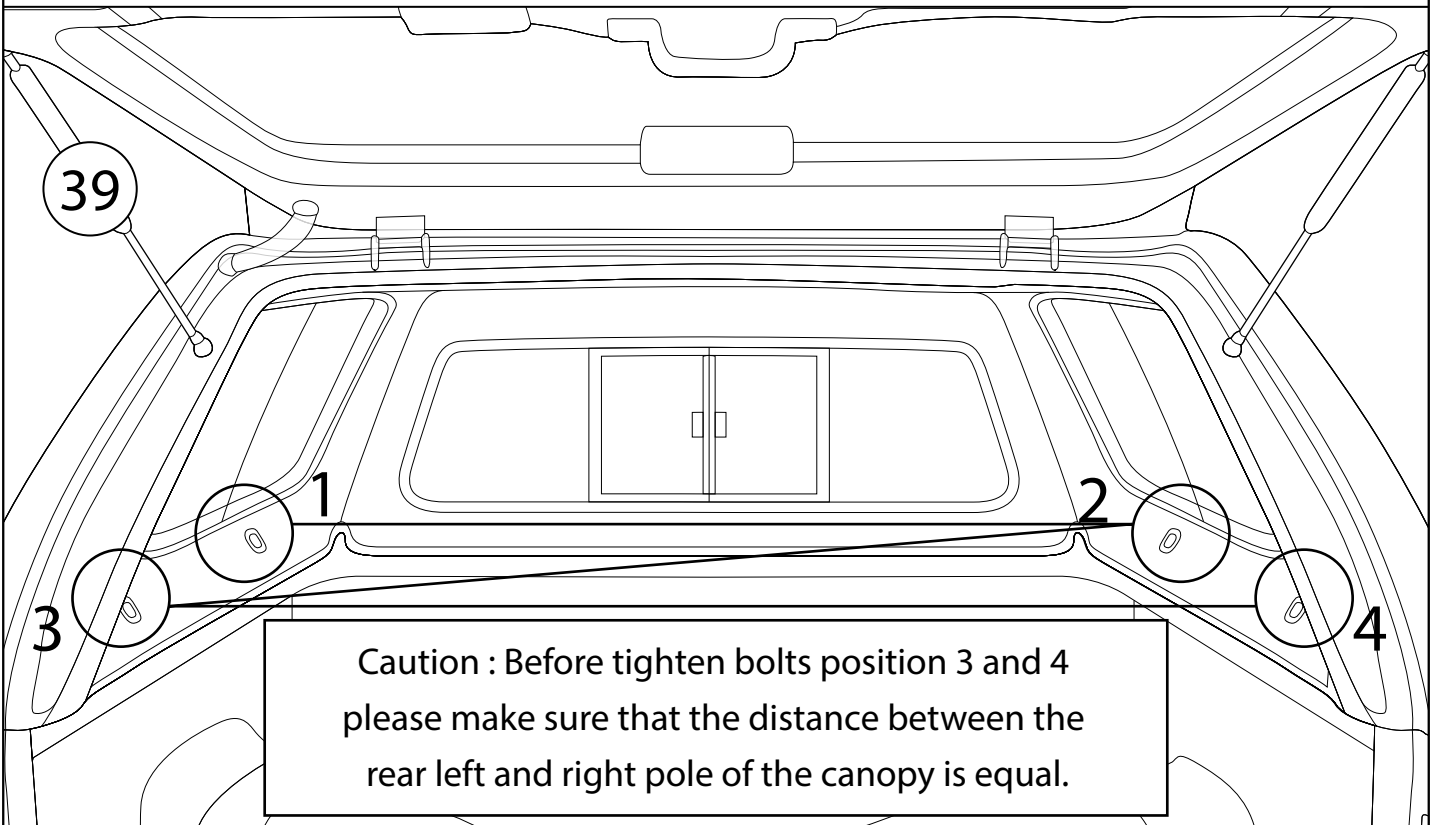

Caution : Before tighten bolts position 3 and 4 please make sure that the distance between the rear left and right pole of the canopy is equal.

Steps of canopy C-Clamp bolts tightening onto vehicle.



40

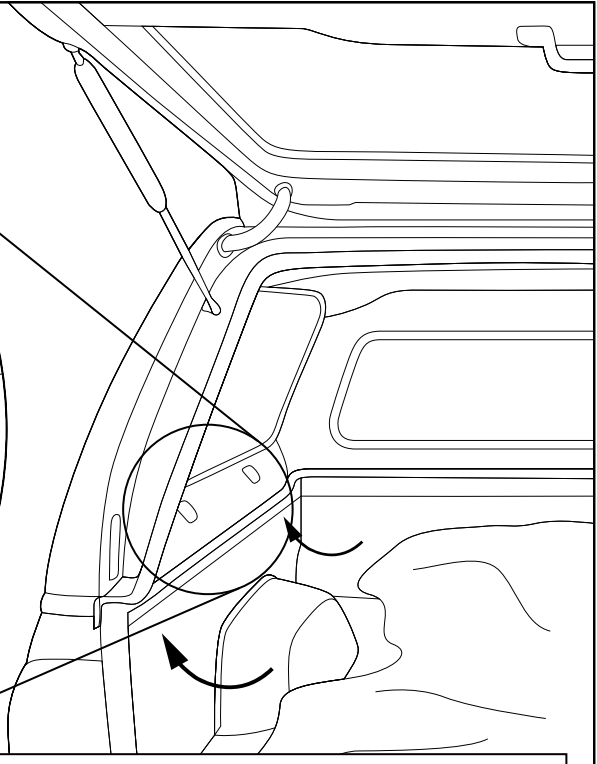
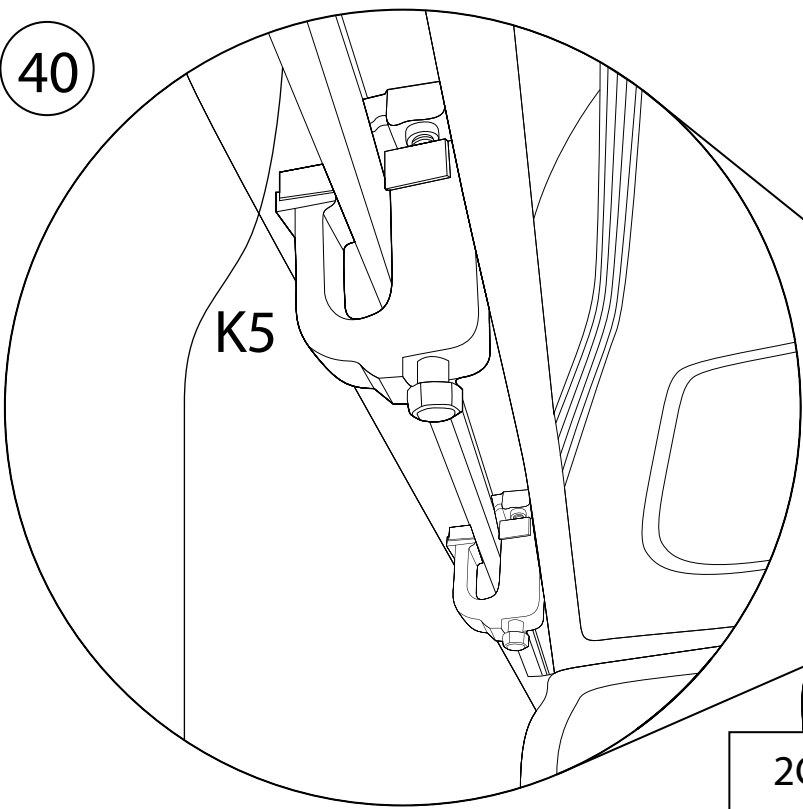

2C-Clamp mounting positions onto vehicle (Left).

41

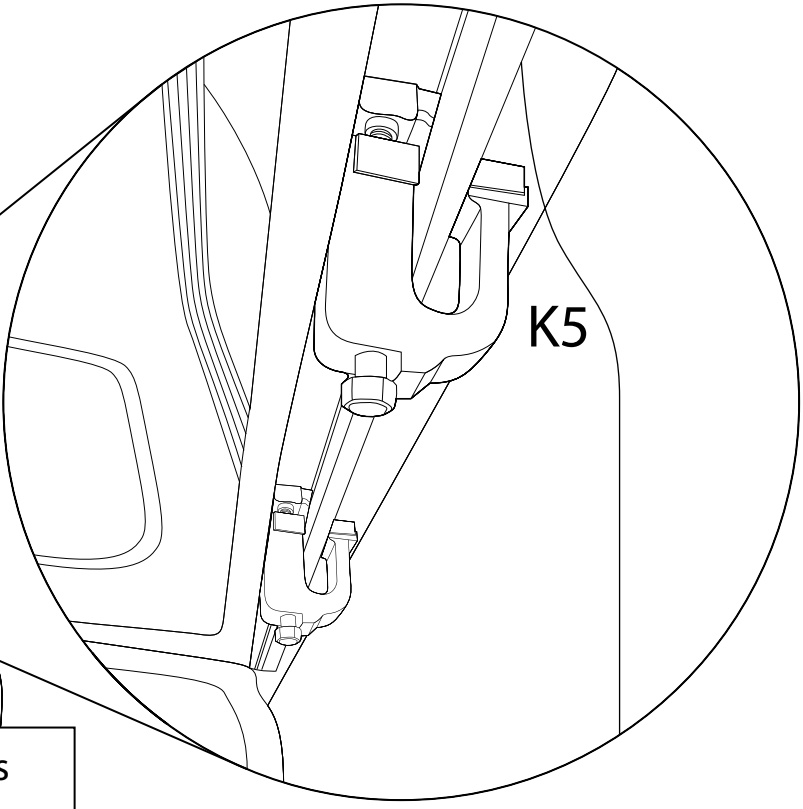
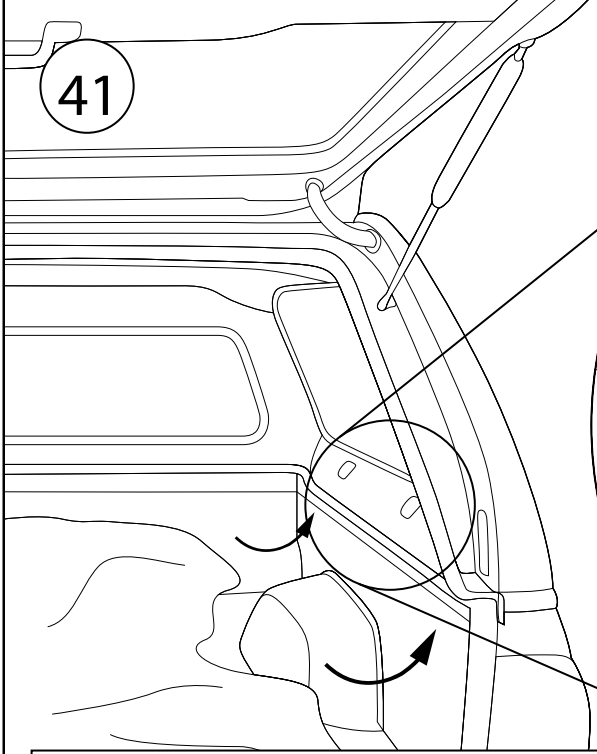

2 C-Clamp mounting positions onto vehicle (Right).

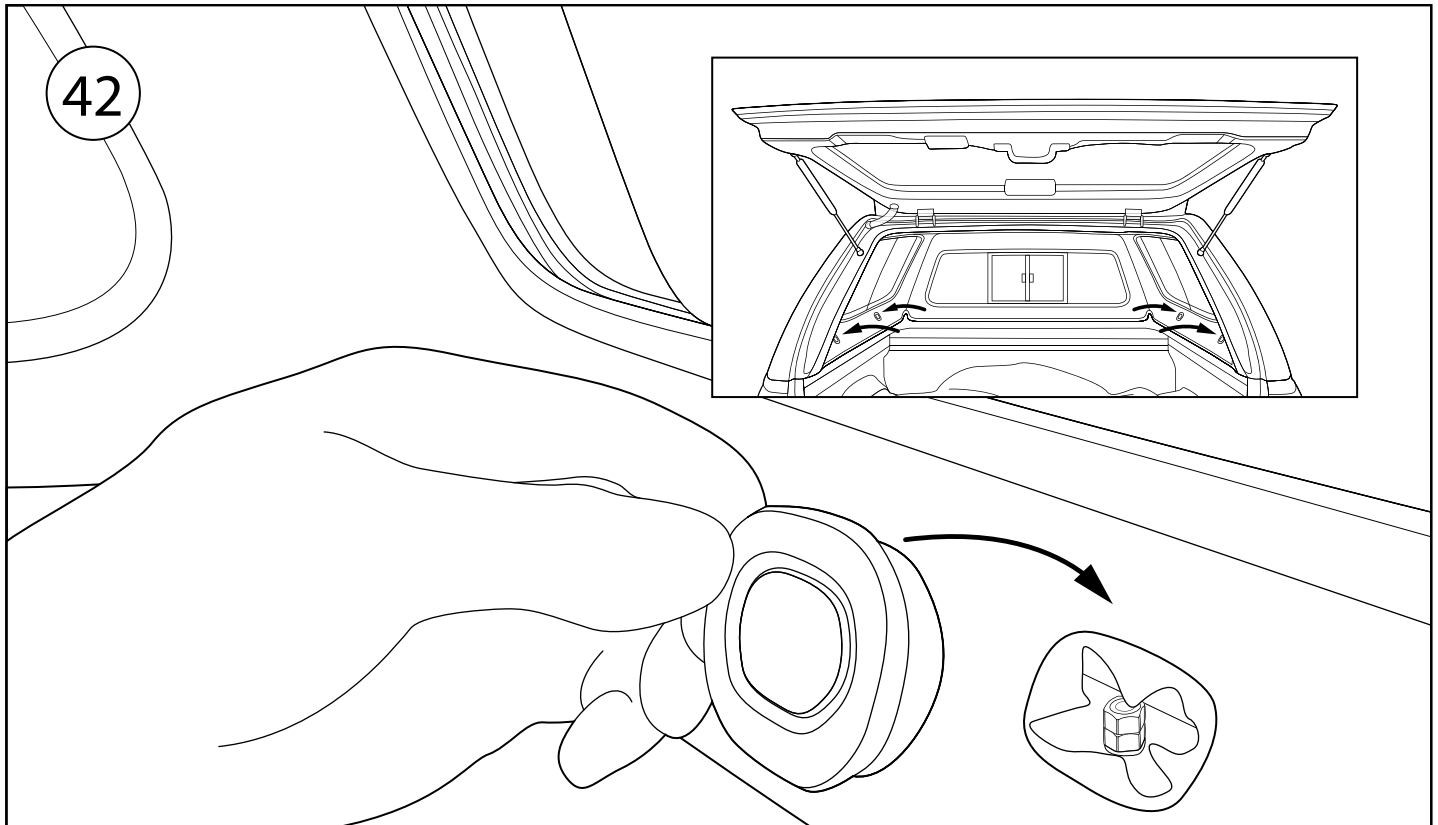

Close the rubber plug.

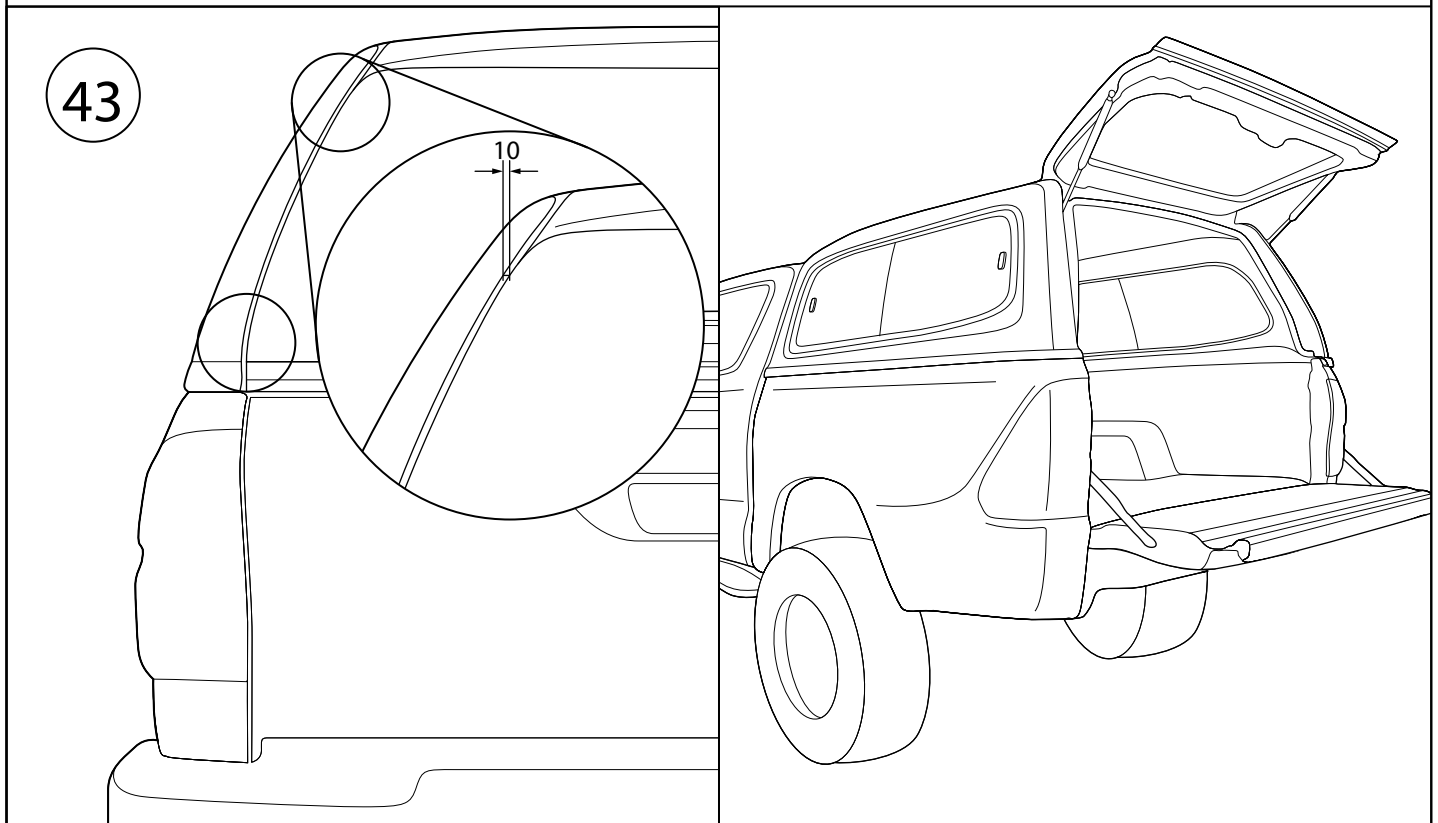

Measure the distance between backdoor and rear pillar, to have the 10 mm. in along the line.

The process of canopy installation is completed.